

**MASONIC MANUAL**  
**and**  
**Monitorial Instructions**  
**of the**  
**Grand Lodge of A. F. & A. M.**  
**of Minnesota**

Revised Edition 1998

Prepared and arranged under the authority  
of the Grand Lodge by the Board of Custodians  
with the assistance of the Research and Education  
Committee and issued with the approval of  
Charles J. Luman, Grand Master.

**PUBLISHED BY**  
**THE GRAND LODGE OF MINNESOTA**  
**1998**



## TABLE OF CONTENTS

Chapter	Page
I	Opening and Closing the Lodge . . . . . 5
	On Freemasonry and Religion . . . . . 15
II	Prerequisites for a Candidate . . . . . 20
III	First Degree . . . . . 24
	On The Secrets of Masonry . . . . . 34
IV	Second Degree . . . . . 36
V	Third Degree . . . . . 50
VI	Installation of Lodge Officers . . . . . 58
VII	Installation of Grand Officers . . . . . 75
VIII	Breaking Ground for Masonic Temple . . . . . 85
IX	Laying Corner Stones . . . . . 88
X	Dedication of Masonic Halls . . . . . 97
XI	Final Masonic Rites . . . . . 108
XII	Lodge of Sorrow . . . . . 116
XIII	Reception of Visitors by a Lodge . . . . . 122
XIV	Presentaton
	Presentation of Fifty Year Emblems . . . . . 126
	Presentation of Widow's Pin . . . . . 128
	Presentation of Hiram Awards . . . . . 131
XV	Musical Notes . . . . . 136

**This book is prepared for the use of the Constituent  
Lodges and members to convey the Masonic  
traditions and customs as practiced in this Grand  
Lodge Jurisdiction and to instruct in the ceremonial forms as  
taught by the Custodians of the Work.**



# CHAPTER I

## OPENING AND CLOSING THE LODGE

The ceremonies for opening and closing a Lodge with solemnity and decorum are universally admitted. These ceremonies are derived from the Constitution, the General Regulations, Masonic usages and customs, and the decisions of the Board of Custodians. While this chapter is fairly complete regarding the opening and closing of a Lodge, there are particular situations where one must refer to the Masonic Code of Minnesota for full information.

To conduct these ceremonies with propriety ought to be the peculiar study of every Mason, especially of those who have the honor to rule in our assemblies. To persons who are thus dignified, every eye is naturally directed for propriety of conduct and behavior; and from them other brethren who are less informed will naturally expect to derive an example worthy of imitation.

From a share in this ceremony no Mason can be exempted. It is a general concern in which all must assist. This is the first request of the Master and the prelude to all business.

When the brethren assemble prior to opening the Lodge, friendly intercourse and social enjoyment are entirely proper. Boisterous and unseemly or undignified conduct are to be avoided.

When the hour for opening has arrived, the Master will take his station and congregate his Lodge. The successful Master will always open his Lodge promptly at the prescribed hour. The Charter of the Lodge, either displayed or in a protective case, must be present in order to open the Lodge. The brethren, properly clothed, will take their seats, and all the officers repair to their respective stations and places. (The apron is always worn on the outside of all clothing, including overcoats.) Care is then taken to see that no person not a

member is allowed to remain unless properly vouched for. The Lodge is then tyled, so that none may pass in or out, except those who are entitled.

At Stated Communications the Lodge is opened on the third degree, and seven members of the Lodge must be present to transact business. The opening of the Lodge on the third degree does not open it on the first or second, so, if a candidate is to be examined, initiated, or passed at a Stated Communication, the Master Mason's Lodge must be called from labor to refreshment. Then, at the discretion of the Master, the Lodge may be either opened or called from refreshment to labor on the first or second degree. After completing such work, the Lodge on the lower degree may then be either called from labor to refreshment or closed in form. The Lodge is then called from refreshment to labor on the third degree and duly closed. The closing of the Lodge on a higher degree does close it in the degree or degrees below it.

At a Special Communication for work, the Lodge, for instance, may be opened on the first degree, the candidate examined, called from labor to refreshment, opened on the second degree, the candidate passed, and the Lodge closed or another candidate examined, called from labor to refreshment, opened on the third degree, and the candidate raised, and the Lodge closed. The closing in the highest degree closes the one or both below it.

## **STATED AND SPECIAL COMMUNICATIONS**

A Lodge meeting is termed a "Communication." There are two types of Communications, "Stated" and "Special."

Stated Communications are the meetings held at the regular times specified in the Lodge By-Laws and are for the purpose of conducting the business of the Lodge. Lodge business includes the programs and events called at the will and pleasure of the Master of

the Lodge and other actions such as paying bills, balloting on petitions, elections, voting on motions, etc.

A Stated Communication must be held at the day, time, and place specified in the By-Laws, unless the Grand Master, by dispensation, has provided otherwise. This is to ensure that any Brother who desires to participate in the Lodge business will not be denied his right.

A Stated Communication must be opened on the Master Mason degree and seven members of the Lodge must be present. (The Grand Master may grant dispensation for a Stated Communication to be held with less than a quorum for a specific purpose.) Visitors from other Lodges can not be counted for the quorum at a Stated Communication. If neither the Master nor the Wardens are present, then any Past Master of the Lodge may open and preside at a Stated Communication. Special Communications are meetings called by the Master for the purpose of examining candidates, conferring degrees, conducting Masonic funerals, or participating in Masonic ceremonies. Candidate examinations and degree work are always done at Communications that are opened (or called from refreshment to labor) on the proper degree. All other Special Communications are opened on the Master Mason degree.

A quorum for a Special Communication is seven Master Masons, and visitors can be counted in this case. If degree work is to be done during a Special Communication, then either the Master or one of the Wardens must be present (though they are not required to take part). Special dispensation from the Grand Master is needed to confer a degree without the Master or Wardens.

All work started at a Communication must be completed at that same Communication, unless special dispensation is obtained from the Grand Master to hold a second Communication on the same day. Thus, all the work of a degree, including the lectures and charges, must be completed during the Communication at which the work was started or during a second, Special Communication held on the same day. In three special cases it is possible to hold a

second Communication on the same day without dispensation from the Grand Master. This can be done if the second Communication is for examining candidates, conducting a Lodge of Sorrow, or conducting a Masonic funeral service.

The officer entitled to preside may allow any qualified Master Mason to preside and to confer degrees in his presence. He may also call upon any qualified Master Mason to fill the station or place of an absent officer.

No Lodge Communication can be held on Sunday except:

1. A Masonic funeral service.
2. An open and public installation or reception.

## **THE TYLER'S DOOR**

Except as specified for degree work, all Brothers enter and leave the Lodge room by way of the Tyler's door. This door is guarded by the Tyler without and the Junior Deacon within the Lodge room. From the first sound of the gavel at opening to the last sound of the gavel at closing, passage through this door is governed by definite rules and conventions. These can be understood easily by assuming that the Tyler's door is locked immediately after the Lodge has been purged and that the Tyler has the only key. Once the door has been locked, it can only be opened by the Tyler at the direction of the Junior Deacon. The Junior Deacon informs the Tyler by knocks and the Tyler responds by opening the door. Should the Tyler desire to open the door to admit a Brother or to convey a message, he gives an alarm and waits for the Junior Deacon's response. There are a number of rules that determine how the Junior Deacon will respond to an alarm from the Tyler. No one is permitted to enter or leave the Lodge during the opening and closing ceremonies, and the Tyler should not give alarms during these times. Until the Lodge is duly opened no alarms are given at the door. When the



Lodge is at labor, the Junior Deacon will not respond to alarms while the Lodge is called up. At other times the Junior Deacon will respond to an alarm after referring it to the Worshipful Master at a convenient time. During degree work or by specific order from the Worshipful Master, alarms are referred to the Senior Warden. The only exception to these rules is during the second section of the Master Mason degree when only the alarm specified in the ritual is given.

## **SALUTES**

Every Mason should be carefully taught the salutes in each degree, and all salutes should be given with precision. No salutes are given until after the S.D. has lit the three burning tapers and opened the Great Lights. He then gives the first salute in Lodge.

## **MANUAL OF THE ROD**

The rods are carried by the Deacons and Stewards as emblems of Office. They are carried in the performance of official duties, either directed or implied, from the sound of the gavel which congregates the Lodge to the sound of the gavel which closes the Lodge. (When the Deacons or Stewards rise as members of the Lodge, they do not pick up their rods.)

Rods are usually carried in the right hand but may be carried in the left hand when occasion requires. Rods must always be held when addressing the Worshipful Master or other officer.

While the Deacons or Stewards are standing, they hold the rod in a perpendicular position, resting it on the floor, in front of the shoulder; the hand grasping the rod so that the forearm is horizontal.

While they are marching, they carry the rod between the upper arm and the body, inclining it forward at an angle of 23 and one-half degrees, grasping the rod at the same position as while standing.

The Senior Deacon does not carry the rod during the second section of the Master Mason degree nor when he carries the ballot box. When his duties require the use of both hands, he may place the rod on the floor, or in a holder, or give it to an assistant.

The Stewards' rods are always in the same room as the Stewards. When giving the interrogatories on the First Degree, the Stewards hold their rods grounded.

## **ORDER OF BUSINESS**

Subject to the By-Laws of the Lodge and the will and pleasure of the Master, the suggested order of business at Stated Communications is as follows:

- a. Ritualistic opening and pledge of allegiance
- b. Greetings and announcements by the Master
- c. Introductions of visiting brothers - Senior Deacon
- d. Community and social events - Junior Warden
- e. Opportunities for relief and assistance - Senior Warden
- f. Program of Masonic Instruction - Lodge Education Officer
- g. Final comments and closing

Balloting, committee reports and other required business matters may be inserted at the Worshipful Master's will and pleasure.

## **APRONS**

The apron is always worn by all Masons present at Lodge meetings. It is also worn during certain public functions for which the Lodge has been opened in private, such as Masonic funerals, public installations and certain Grand Lodge ceremonies. The apron is worn on the outside of all clothing, including overcoats. The apron is never worn under another garment. Any Master Mason should gently remind his lesser informed Brother of this fact.

## **PRAYER AT OPENING**

Most holy and glorious Lord God, the great Architect of the Universe, the Giver of all good gifts and graces! Thou hast promised that “where two or three are gathered together in Thy name Thou wilt be in the midst of them and bless them.” In Thy name we have assembled, and in Thy name we desire to proceed in all our doings. Grant that the sublime principles of Freemasonry may so subdue every discordant passion within us; so harmonize and enrich our hearts with Thine own love and goodness - that the Lodge at this time may humbly reflect that order and beauty which reign forever before Thy throne.—Amen.

**Response:** So mote it be.

## **A SHORTER OPENING PRAYER**

Supreme Architect of the Universe: We invoke Thy blessing at this time! May this meeting, thus begun in order, be conducted in peace, and closed in harmony!—Amen.

**Response:** So mote it be.

## **ALTERNATE OPENING PRAYER**

Most holy and glorious Lord God, the great Architect of the Universe, the Giver of all good gifts and graces! You have promised that “where two or three are gathered together in Your name You will be in the midst of them and bless them.” In Your name we have assembled, and in Your name we desire to proceed in all our doings. Grant that the sublime principles of Freemasonry may so subdue every discordant passion within us—so harmonize and enrich our hearts with Your own love and goodness—that the Lodge at this time may humbly reflect that order and beauty which reign forever before Your throne.—Amen.

**Response:** So mote it be.

## SHORT ALTERNATE PRAYER

Supreme Architect of the Universe: We invoke Your blessing at this time! May this meeting, thus begun in order, be conducted in peace, and closed in harmony!—Amen.

**Response:** So mote it be.

The following opening Ode may be sung:

Air: Dundee or Ortonville

Within our Temple met again,  
With hearts and purpose strong,  
We'll raise our notes of grateful praise,  
With union in our song.  
Around our altar's sacred shrine  
May love's pure incense rise,  
Bearing upon its mystic flame  
Our music to the skies.

Air: America

Glad hearts to thee we bring,  
With joy thy name to sing, Father above.  
Creation praises thee:  
Thy bounty's full and free.  
In all around we see Emblems of love.  
Unite our souls in love;  
Smile on us from above Till life is o'er.  
Then gather us to Thee,  
Thy kingdom, Lord, to see  
In thine own fold to be, Forevermore.

Some of the Odes given in this manual are sung to tunes that are no longer in common use. These tunes (or Airs) can be found in Chapter XV of this book.

## PRAYER AT CLOSING

Supreme Architect of the Universe! Accept our humble thanks for the many mercies and blessings which Thy bounty has conferred on us, and especially for this friendly and social intercourse. Pardon, we beseech Thee, whatever Thou hast seen amiss in us since we have been together, and continue to us Thy presence, protection, and blessing. Make us sensible of the renewed obligations we are under to love Thee, and as we are about to separate, and return to our respective places of abode, wilt Thou be pleased so to influence our hearts and minds that we may each one of us practice, out of the Lodge, those great moral duties which are inculcated in it, and with reverence study and obey the laws which Thou has given us in Thy Holy Word. Amen.

**Response:** So mote it be.

## ALTERNATE CLOSING PRAYER

Supreme Architect of the Universe! Accept our humble thanks for the many mercies and blessings which Your bounty has conferred on us, and especially for this friendly and social intercourse. Pardon, we ask, whatever You have seen amiss in us since we have been together, and continue to us Your presence, protection, and blessing. Make us sensible of the renewed obligations we are under to love You, and as we are about to separate, and return to our respective places of abode, will You be pleased so to influence our hearts and minds that we may each one of us practice, out of the Lodge, those great moral duties which are inculcated in it, and with reverence study and obey the laws which You have given us in Your Holy Word. Amen.

**Response:** So mote it be. Response: So mote it be.

## CHARGE AT CLOSING

Brethren, you are now to quit this sacred retreat of friendship and virtue to mix again with the world. Amidst its concerns and employments, forget not the duties you have heard so frequently inculcated and forcibly recommended in this Lodge. Be diligent, prudent, temperate, discreet. Remember that around this altar you have promised to befriend and relieve every brother who shall need your assistance. Remember that you have promised to remind him, in the most tender manner, of his failings, and aid his reformation; to vindicate his character when wrongfully traduced; suggest, in his behalf, the most candid and favorable circumstances. Is he justly reprimanded? Let the world observe how Masons love one another.

These generous principles are to extend further. Every human being has a claim upon your kind offices. Do good unto all. Recommend it more especially “to the household of the faithful.”

By diligence in the duties of your respective callings; by liberal benevolence and diffusive charity; by constancy and fidelity in your friendships, discover the beneficial and happy effects of this ancient and honorable Institution. Let it not be supposed that you have here labored in vain and spent your strength for naught; for your work is with the Lord and your recompense with God.

Finally, brethren, be ye all of one mind; live in peace, and may the God of love and peace delight to dwell with and bless you!

The following closing Ode may be sung—

**Air: Sicilian Hymn**

Now our social labors closing,  
Homage of the heart we pay;  
Each in confidence reposing,  
Kindest thoughts that ne'er decay.  
Let us each, in Time's commotion,  
Heavenly light and truth implore;  
Thus we'll pass life's stormy ocean,  
Landing on a happier shore.

**BENEDICTION AT CLOSING**

May the blessing of Heaven rest upon us and all regular Masons!  
May brotherly love prevail, and every moral and social virtue  
cement us!

**MASONRY AND RELIGION**

Masonry does not profess to be a religion, although it is obviously religious in character. It also does not pretend to take the place of religion, nor serve as a substitute for the religious beliefs of its members.

Freemasonry will open its doors to all men regardless of their religious conviction, the essential requirements in this regard being an avowed belief in God and expected punishment for vice and reward for virtue. (See the first Ancient Landmark in the Grand Lodge Constitution, Section **C2.03 (1)** That belief in the Supreme Being, “The Great Architect of the Universe,” who will punish vice and reward virtue, is an indispensable prerequisite to admission to Masonry.)

**MINNESOTA'S OFFICIAL POSITION**

The National Masonic Information Center proposes the following statement concerning Freemasonry and religion and is

encouraging Grand Lodges throughout the United States to adopt this statement so that they will have a common position regarding this religious issue.

The Grand Lodge A.F. & A.M. of Minnesota adopted the following statement as a standing resolution at its 1996 Annual Communication:

**Basic Principles** Freemasonry is not a religion, nor is it a substitute for religion. Freemasonry requires of its members belief in God as part of the obligation of every responsible adult, but advocates no sectarian faith or practice. Masonic ceremonies include prayers, both traditional and extempore, to reaffirm each individual's dependence on God and to seek divine guidance. Freemasonry is open to men of any faith, but religion may not be discussed at Masonic meetings.

**The Supreme Being** Masons believe that there is one God and that people employ many different ways to seek and to express what they know of God. Masons primarily uses the appellation, "Grand Architect of the Universe," and other non-sectarian titles, to address Deity. In this way, persons of different faiths may join together in prayer, concentrating on God rather than on differences among themselves. Masonry believes in religious freedom and that the relationship between the individual and God is personal, private, and sacred.

**Volume of the Sacred Law** An open volume of the Sacred Law, "the rule and guide of life," is an essential part of every Masonic meeting. The Volume of the Sacred Law to a Christian is the Bible; to Freemasons of other faiths, it is the book held holy by them.

**The Oath of Freemasonry** The obligations taken by Freemasons are sworn on the Volume of the Sacred Law. They are undertakings to follow the principles of Freemasonry and to keep confidential a Freemason's means of recognition. The much-discussed penalties are judicial remnants from an earlier era and are symbolic, not literal. They refer only to the pain any honest man should feel at the thought of violating his word.



**Freemasonry Compared with Religion** Freemasonry lacks the basic elements of religion: (a) It has no dogma or theology, no wish or means to enforce religious orthodoxy. (b) It offers no sacraments. (c) It does not claim to lead to salvation by works, by secret knowledge, or by any other means. The secrets of Freemasonry are concerned with modes of recognition, not with the means of salvation.

Freemasonry Supports Religion Freemasonry is far from indifferent toward religion. Without interfering in religious practice, it expects each member to follow his own faith and to place his Duty to God above all other duties. Its moral teachings are acceptable to all religions.

### **Concerning Prayer**

Masonic custom dictates that the Lodge be opened and closed with prayer. It is always proper to address the Supreme Being as “The Great Architect of the Universe.”

Addressing the Deity in prayer at Masonic functions should never be done in a way that excludes Brothers of other faiths and of necessity should be inclusive and universal, not sectarian or denominational.

### **Display of Flags**

Every Masonic Lodge should have the American flag displayed to the right of the Master’s podium in the East and the other national flags or the Minnesota Masonic flag displayed to the left. It is never proper to display the flag of any religious group or faith tradition in a Masonic Lodge when conducting Stated or Special Communications.

### **The Volume of Sacred Law**

An open volume of Sacred Law (Holy Bible) which includes the Old and New Testaments shall be displayed upon the altar at all Stated and Special Communications. When Brothers of other faith traditions who have taken their vows on a different Volume of

Sacred Law are present, it is proper and salutary to display on the altar the Volume of Sacred Law which they honor and revere. This practice conforms to the highest ideals of our Craft in respect for the various faith traditions of our members when in Lodge assembled.

The vows of the candidate's initiation must be taken upon the Volume of Sacred Law that will bind them to the solemn obligations of our Fraternity. Each candidate for Masonic initiation should be asked, prior to the first degree, what Volume of Sacred Law they revere as their Great Light in Masonry. If a candidate desires to provide a Volume of Sacred Law other than the Lodge's, he may do so and his obligations can be taken upon that book. Separate books can be used for each candidate.

## **POINTS OF INFORMATION**

When the Lodge is at labor, only the Three Great Lights may be upon the altar, except that during the conferring of degrees the candidates may place their hands upon the altar.

Either hand may be used when voting.

The lectures are part of the degrees and must not be omitted. (Second Section of the Fellowcraft Degree Lecture was made an optional lecture by vote of Grand Lodge Assembly in 1997)

## **REFERENCES**

### **Constitution:**

**SECTION C9.18** Para.(d) Definition of Stated Communication, Quorum.

**SECTION C9.18** Para.(e) Meeting on Sunday.

### **General Regulations:**

**SECTION G13.06** Past Master presiding on a Stated Communication.

**SECTION G13.06** Calling any well-informed Master Mason to preside.

**SECTION G13.10** Special and Stated Communications.

**SECTION G13.21** Opening and closing the Lodge in private for a public ceremony.

**SECTION G13.22** Hour of opening a Stated Communication.

**SECTION G13.23** Work completed at same Communication.

**SECTION G14.15** Degrees cannot be communicated or abbreviated.

## CHAPTER II

### PREREQUISITES FOR A CANDIDATE

To become a petitioner for the degrees in Masonry, a man must believe and trust in God, and without previous improper solicitation on the part of any Mason, must have indicated first a desire to be made a Mason. His petition, (if he is otherwise eligible) may be received, if it is accompanied by an amount not less than one-third of the whole fee for degrees, and if it is recommended by at least two brethren of the Lodge. Blank petitions for the degrees should never be handed out to non-Masons.

In accordance with the principles and the Ancient Landmarks of Masonry, every petition for membership shall be received and acted on without regard to the race, color, creed, or national origin of the petitioner.

Petitions when properly filled out should be filed with the Secretary of the Lodge and read by him at the first Stated Communication thereafter. If the petitioner appears from such petition to be eligible as to age and territorial jurisdiction, it may be received and referred to three brethren of the Lodge as a committee to investigate the statements in the petition, and particularly as to territorial jurisdiction and the moral, intellectual, social, and physical qualifications of the petitioner. The names of the committeemen are not to be recorded in the minutes or elsewhere.

Each member of the committee will act independently in making his investigation, and no one, except the Master and the Secretary, will know who the committeemen are. A report should be made by each, if practicable, by the next Stated Communication after their appointment. A request for further time should be made by a committeeman desiring it through the Master or Secretary in case it is necessary to complete the investigation and may then be granted.

The law requires a full written report by each committeeman upon a proper blank which he will receive from the Secretary. The Lodge may accept by vote the reports of a majority of the committee or may insist upon a report from all. When a report has been so made or accepted, the report of each member of the committee is separately read (omitting his name.) If the Lodge has territorial jurisdiction of the petitioner and he is eligible as to length of residence, the ballot will be spread immediately and without discussion, whether the report is favorable or unfavorable, except that in case of the unanimous favorable report, a petitioner may be allowed to withdraw his petition without ballot by the unanimous vote of the Lodge. If the reports show lack of territorial jurisdiction or insufficient residence, the petition, with the fee, must be returned without vote or ballot. The reports of the committee are to be destroyed immediately after the ballot.

## **METHOD OF BALLOTING**

The Master orders: “Brother Senior Deacon, prepare the ballot-box.”

Senior Deacon proceeds to do so.

Master, or Secretary, reads the petition. (Once a petitioner’s name is read, no one can leave or enter the Lodge room until the ballot is completed.)

Master, or Secretary, reads the reports of the Committee.

Master announces: “Brethren, you are about to vote on the petition for Degrees (Affiliation) (Restoration) (Reinstatement) of Mr., (Brother) . Be careful of your ballot and see that no mistakes occur. White balls elect, black balls or cubes reject.”

Senior Deacon then presents the ballot-box to Master who examines it and, if found in order, Master votes.

Senior Deacon then proceeds to Senior Warden by way of the North and Senior Warden votes; then to Junior Warden; then to East, south of Master; and proceeds by way of the South, each member rising and voting in turn, (every member present must vote), completing the circuit in East, to north of Master. Senior Deacon then votes and proceeds to west of Altar.

Master then asks: “Brother Senior Deacon, have all the members voted?”

Senior Deacon, saluting, reports: “All the members have voted, Worshipful Master.”

Master then says: “I declare the ballot closed.” Confirms with gavel.

Senior Deacon then proceeds without order to Junior Warden’s Station and presents the ballot-box to that Officer for examination; proceeding immediately to Senior Warden’s Station for examination by that Officer. While Senior Deacon is proceeding South to West, Master asks: “How stands the ballot in the South, Brother Junior Warden?” Junior Warden, saluting, reports: “Clear (or dark) in the South, Worshipful Master.” While Senior Deacon is proceeding to East, Master asks: “How stands the ballot in the West, Brother Senior Warden?” Senior Warden, saluting, reports: “Clear (or dark) in the West, Worshipful Master.” Senior Deacon, by then having arrived at Worshipful Master’s Station, presents ballot-box to Master, who examines it; and having first destroyed ballot, says, “Clear (or dark) in the East. I therefore declare Mr. elected to receive the Degrees as conferred by Lodge; or, Brother elected to membership in Lodge; or Brother restored to membership in Lodge.” Confirms with gavel.

If the ballot is dark, Master says: “I therefore declare the petition of Mr. (Brother) rejected.” Confirms with gavel.

If the ballot taken contains but one black ballot, the Master, in his discretion, may order one other ballot taken immediately,—to assure himself that no mistake has occurred,—not otherwise, and no

more. The Master must destroy the ballot immediately after he examines it, by emptying the box, before announcing the result.

(Upon rejection, the Worshipful Master must immediately read Section G6.03 (d) and (f) of the general regulations.)

If the petitioner has been accepted by ballot, he is entitled to receive his degree, at the reasonable will and pleasure of the Master and must present himself for initiation, when notified by the Secretary, unless the Lodge for cause excuses the delay; otherwise, after a year, he must present a new petition, which will take the same course as his first petition.

**(SECTION G6.03** Beside violation of Section C8.01, of the Constitution, the following specific acts shall be deemed unmasonic conduct and shall render the offender subject to discipline.

**(d)** To discuss the character or the merits or demerits of a petitioner, either for degrees or membership, in a Lodge convened or, after rejection, to express regret at the action taken, or how he or anyone voted upon the ballot.

A violation of paragraph (d) shall require immediate charges filed with the Master and, if found guilty, the penalty shall be expulsion and no other.

Whenever a petition either for degrees or membership is rejected by a vote of the Lodge, paragraph (d) of Section G6.03 of this Article shall immediately be read to the Lodge, in an audible voice, as a warning.

**(f)** To declare that there shall be no more petitioners accepted, or to blackball a petitioner for spite.)

## CHAPTER III

### FIRST DEGREE

The first degree is divided into two sections: the work and the lecture. The work proceeds as follows:

#### FIRST SECTION

A candidate who presents himself for initiation is taken to the preparation room. The Stewards alone meet him there, collect the fee and propound the following: Every candidate, previous to his reception, is required to give his free and full assent to the following interrogatories:

(During the interrogatories the Stewards stand with rods grounded, in order to create a dignified impression. The candidate(s) will stand facing the Stewards. Only the Stewards and candidates are in the preparation room at this time.)

1. Do you seriously declare, upon your honor, before these gentlemen, that, unbiased by friends, and uninfluenced by mercenary motives, you freely and voluntarily offer yourself a candidate for the mysteries of Masonry?

2. Do you seriously declare, upon your honor, before these gentlemen, that you are prompted to solicit the privileges of Masonry, by a favorable opinion conceived of the Institution, a desire of knowledge, and a sincere wish of being serviceable to your fellow creatures?

3. Do you seriously declare, upon your honor, before these gentlemen, that you will cheerfully conform to all the ancient established usages and customs of the Fraternity?

If the proper answers have been made, the preparatory lecture will then be given, and the candidate prepared for initiation.



## PRAYER AT INITIATION

Vouchsafe Thine aid, Almighty Father of the Universe, to this, our present convention; and grant that this candidate for Masonry may dedicate and devote his life to Thy service, and become a true and faithful brother among us! Endue him with a competency of Thy divine wisdom, that by the secrets of our art, he may be better enabled to display the beauties of Brotherly Love, Relief and Truth, to the honor of Thy holy name!—Amen.

**Response:** So mote it be.

### Psalm CXXXIII

- Behold, how good and how pleasant it is for brethren to dwell together in unity!
- It is like the precious ointment upon the head, that ran down upon the beard, even Aaron's beard: that went down to the skirts of his garments.
- As the dew of Hermon, and as the dew that descended upon the mountains of Zion: for there the Lord commanded the blessing, even life for evermore.

Instead of scripture reading, the following paraphrase of same may be sung:

### Air: Auld Lang Syne

(Music printed in Chapter XV with traditional words)

Behold! how pleasant and how good, For brethren such as we,  
Of the accepted brotherhood, To dwell in unity!  
'Tis like the oil on Aaron's head, Which to his feet distills;  
Like Hermon's dew so richly shed On Zion's sacred hills.  
For there the Lord of light and love  
A blessing sent with power:  
Oh, may we all this blessing prove, E'en life forevermore.  
On friendship's altar, rising here,  
Our hands now plighted be,  
To live in love, with hearts sincere, In peace and unity.

It is a duty incumbent on every Master of a Lodge before the ceremony of initiation takes place, to inform the candidate of the purpose and design of the Institution; to explain the nature of his solemn engagements; and, in a manner peculiar to Masons alone, to require his cheerful acquiescence to the duties of morality and virtue and all the sacred tenets of the Fraternity.

Towards the close of the first section is explained that peculiar sign of Masonry, the LAMBSKIN, or white leather apron, which is an emblem of innocence and the badge of a Mason; more ancient than the Golden Fleece or Roman Eagle, more honorable than the Star and Garter, or any other Order that could be conferred upon the candidate at the time of his initiation or at any time thereafter, by king, prince, potentate, or any other person, except he be a Mason, and which every Mason ought to wear with equal pleasure to himself and honor to the Fraternity.

This is followed by an explanation of the working tools and implements of an Entered Apprentice, which are the Twenty-four inch Gauge, and the Common Gavel.

The TWENTY-FOUR INCH GAUGE is an instrument made use of by Operative Masons, to measure and lay out their work; but we, as Free and Accepted Masons, are taught to make use of it for the more noble and glorious purpose of dividing our time. It being divided into twenty-four equal parts, is emblematical of the twenty-four hours of the day, which we are taught to divide into three equal parts, whereby we find eight hours for the service of God and a distressed worthy brother; eight hours for our usual avocations; and eight for refreshment and sleep. The COMMON GAVEL is an instrument made use of by operative Masons, to break off the corners of rough stones, the better to fit them for the builder's use; but we, as Free and Accepted Masons, are taught to make use of it for the more noble and glorious purpose of divesting our minds and consciences of all the vices and superfluities of life; thereby fitting our

bodies, as living stones, for that spiritual building, that house not made with hands, eternal in the heavens.

## **CHARGE AT INITIATION**

**BROTHER**, as you are now introduced into the first principles of Masonry, I congratulate you on being accepted into this Ancient and Honorable Fraternity; ancient, as having subsisted from time immemorial; and honorable, as tending, in every particular, so to render all men who will be conformable to its precepts. No institution was ever raised on a better principle, or more solid foundation; nor were ever more excellent rules and useful maxims laid down, than are inculcated in the several Masonic lectures. The greatest and best of men in all ages have been encouragers and promoters of the art, and have never deemed it derogatory from their dignity to level themselves with the Fraternity, extend their privileges, and patronize their assemblies.

There are three great duties, which, as a Mason, you are charged to inculcate to God, your neighbor, and yourself. To **GOD**, in never mentioning His name, but with that reverential awe which is due from a creature to his Creator; to implore His aid in all your laudable undertakings, and to esteem him as the chief good; to your **NEIGHBOR**, in acting upon the square, and doing unto him as you wish he should do unto you; and to **YOURSELF**, in avoiding all irregularity and intemperance, which may impair your faculties, or debase the dignity of your profession. A zealous attachment to these duties will insure public and private esteem.

In the State, you are to be a quiet and peaceful subject, true to your government, and just to your country; you are not to countenance disloyalty or rebellion, but patiently submit to legal authority and conform with cheerfulness to the government of the country in which you live.

In your outward demeanor be particularly careful to avoid censure or reproach. Let not interest, favor, or prejudice, bias your integrity, or influence you to be guilty of a dishonorable action. Although your frequent appearance at our regular meetings is earnestly solicited, yet it is not meant that Masonry should interfere with your necessary vocations; for these are on no account to be neglected, neither are you to suffer your zeal for the Institution to lead you into argument with those who, through ignorance, may ridicule it. At your leisure hours, that you may improve in Masonic knowledge, you are to converse with well-informed brethren, who will be always as ready to give, as you will be ready to receive instruction.

Finally: keep sacred and inviolable the mysteries of the Fraternity, as these are to distinguish you from the rest of the community, and mark your consequence among Masons. If, in the circle of your acquaintance, you find a person desirous of being initiated into Masonry, be particularly attentive not to recommend him, unless you are convinced he will conform to our rules; that the honor, glory, and reputation of the Institution may be firmly established and the world at large convinced of its good effects.

## **SECOND SECTION**

The second section rationally accounts for the origin of our hieroglyphical instruction, and convinces us of the advantages which will ever accompany a faithful observance of our duty; it maintains, beyond the power of contradiction, the propriety of our rites, while it demonstrates to the most skeptical and hesitating mind, their excellence and utility; it illustrates, at the same time, certain particulars, of which our ignorance might lead us into error, and which, as Masons, we are indispensably bound to know.

## THE BADGE OF A MASON

Every candidate, at his initiation, is presented with a Lambskin, or white leather apron.

The LAMB has in all ages been deemed an emblem of innocence; he, therefore, who wears the lambskin as a badge of Masonry is thereby continually reminded of that purity of life and conduct, which is essentially necessary to his gaining admission into the Celestial Lodge above, where the Supreme Architect of the Universe presides.

From east to west Freemasonry extends, and between the north and south in every clime and nation, are Masons to be found.

Our Institution is said to be supported, by WISDOM, STRENGTH and BEAUTY; because it is necessary there should be wisdom to contrive, strength to support and beauty to adorn, all great and important undertakings. Its dimensions are unlimited, and its covering no less than the canopy of heaven. To this object the Mason's mind is continually directed, and thither he hopes at last to arrive by the aid of the theological ladder, which Jacob, in his vision, saw ascending from earth to heaven; the three principal rounds of which are denominated FAITH, HOPE and CHARITY, and which admonish us to have faith in God, hope in immortality, and charity to all mankind.

Every well governed lodge is furnished with the HOLY BIBLE, SQUARE and COMPASS. The BIBLE points out the path that leads to happiness, and is dedicated to God; the SQUARE teaches us to regulate our conduct by the principles of morality and virtue and is dedicated to the Master; the COMPASS teaches us to limit our desires in every station, and is dedicated to the Craft.

The BIBLE is dedicated to the service of God, because it is the inestimable gift of God to man • • • , the SQUARE to the Master, because, being the proper Masonic emblem of his office, it is con-

stantly to remind him of the duty he owes to the Lodge over which he is appointed to preside, and the COMPASS to the Craft, because by a due attention to its use, they are taught to regulate their desires and keep their passions within due bounds.

The ornamental parts of a Lodge, displayed in this section, are the Mosaic Pavement, the Indented Tessel, and the Blazing Star.

The MOSAIC PAVEMENT is a representation of the ground floor of King Solomon's Temple; the INDENTED TESSEL, that beautiful tessellated border, or skirting which surrounded it, and the BLAZING STAR, in the center, is commemorative of the star which appeared to guide the wise men of the east to the place of our Savior's nativity. The Mosaic Pavement is emblematic of human life, checkered with good and evil; the beautiful border which surrounds it, those blessings and comforts which surround us, and which we hope to obtain by a faithful reliance on Divine Providence, which is hieroglyphically represented by the Blazing Star in the center.

The movable and immovable jewels also claim our attention in this section.

The ROUGH ASHLAR is a stone as taken from the quarry in its rude and natural state. The PERFECT ASHLAR is a stone made ready by the hands of the workman, to be adjusted by the tools of the Fellow Craft. The TRESTLE BOARD is for the Master Workman to draw his designs upon.

By the ROUGH ASHLAR, we are reminded of our rude and imperfect state by nature; by the PERFECT ASHLAR, that state of perfection at which we hope to arrive, by a virtuous education, our own endeavors, and the blessing of God; and by the TRESTLE BOARD, we are reminded that as the operative workman erects his temporal building agreeably to the rules and designs laid down by

the master on his Trestle Board, so should we, both operative and speculative, endeavor to erect our spiritual building agreeably to the rules and designs laid down by the Supreme Architect of the Universe, in the Book of Life, which is our spiritual Trestle Board.

Our ancient brethren dedicated their Lodges to King Solomon. Masons professing Christianity dedicate theirs to St. John the Baptist, and St. John the Evangelist, who were eminent patrons of Masonry; and since their time there is represented in every regular and well-governed Lodge, a certain Point within a Circle; the Point representing an individual brother, the Circle representing the boundary line of his duty to God and man, beyond which he is never to suffer his passions, prejudices or interests to betray him on any occasion. This Circle is embordered by two perpendicular parallel lines, representing St. John the Baptist and St. John the Evangelist, who were perfect parallels, in Christianity as well as Masonry; and upon the vertex rests the Book of Holy Scriptures which point out the whole duty of man. In going round this circle, we necessarily touch upon these two lines, as well as upon the Holy Scriptures; and while a Mason keeps himself thus circumscribed, it is impossible that he should materially err.

BROTHERLY LOVE, RELIEF AND TRUTH are themes on which we here expatiate.

### **OF BROTHERLY LOVE**

By the exercise of BROTHERLY LOVE, we are taught to regard the whole human species as one family, the high and low, the rich and poor; who, as created by one Almighty Parent, and inhabitants of the same planet, are to aid, support and protect each other. On this principle Masonry unites men of every country, sect and opinion, and conciliates true friendship among those who might otherwise have remained at a perpetual distance.

## **OF RELIEF**

To RELIEVE the distressed is a duty incumbent on all men; but particularly on Masons, who are linked together by an indissoluble chain of sincere affection. To soothe the unhappy, to sympathize with their misfortunes, to compassionate their miseries, and to restore peace to their troubled minds, is the grand aim we have in view. On this basis we form our friendships, and establish our connections.

## **OF TRUTH**

TRUTH is a divine attribute, and the foundation of every virtue. To be good and true, is the first lesson we are taught in Masonry. On this theme we contemplate, and by its dictates endeavor to regulate our conduct. Hence, while influenced by this principle, hypocrisy and deceit are unknown among us, sincerity and plain dealing distinguish us, and the heart and tongue join in promoting each other's welfare, and rejoicing in each other's prosperity.

To this illustration succeeds an explanation of the four cardinal virtues—Temperance, Fortitude, Prudence and Justice.

## **OF TEMPERANCE**

TEMPERANCE is that due restraint upon our affections and passions, which renders the body tame and governable, and frees the mind from the allurements of vice. This virtue should be the constant practice of every Mason, as he is thereby taught to avoid excess, or contracting any licentious or vicious habit, the indulgence of which might lead him to disclose some of those valuable secrets which he has promised to conceal and never reveal, and which would consequently subject him to the contempt and detestation of all good Masons, • • •



## **OF FORTITUDE**

FORTITUDE is that noble and steady purpose of the mind, whereby we are enabled to undergo any pain, peril or danger, when prudentially deemed expedient. This virtue is equally distant from rashness and cowardice; and, like the former, should be deeply impressed upon the mind of every Mason, as a safeguard or security against any illegal attack that may be made, by force or otherwise, to extort from him any of those secrets with which he has been so solemnly intrusted, and which was emblematically represented upon his first admission into the lodge, • • •

## **OF PRUDENCE**

PRUDENCE teaches us to regulate our lives and actions agreeably to the dictates of reason, and is that habit by which we wisely judge and prudentially determine, on all things relative to our present, as well as to our future happiness. This virtue should be the peculiar characteristic of every Mason, not only for the government of his conduct while in the Lodge, but also when abroad in the world. It should be particularly attended to in all strange and mixed companies, never to let fall the least sign, token or word, whereby the secrets of Masonry might be unlawfully obtained, • • •

## **OF JUSTICE**

JUSTICE is that standard, or boundary, of right, which enables us to render to every man his just due, without distinction. This virtue is not only consistent with divine and human laws, but is the very cement and support of civil society; and, as Justice in a great measure constitutes the real good man, so should it be the invariable practice of every Mason never to deviate from the minutest principles thereof, • • •

## **THE SECRETS OF MASONRY**

Every Entered Apprentice should be informed of the following basic principles and information.

### **What You Can Discuss With a Non-Mason**

Masonry is not a secret society. Members of our lodges are not in anyway forbidden from telling others that they are Masons. While every Mason should remember his obligations to secrecy, yet we want to inform non-masons about who we are, what we are, and what we do. Therefore it is important that every Mason understand clearly which things he can talk about and which things he cannot.

### **What Is a Masonic Secret**

What are the things we call the secrets of Masonry? The first secret is the ballot of a Mason. No one can know how a Mason votes, unless that Mason tells him, and that is considered unmasonic conduct. The right and privilege of casting a secret ballot is universally respected in this country by Masons and non-masons alike.

Other secrets are:

- the modes of recognition (signs and words);
- the obligations or vows of each degree;
- the manner of conferring the degrees, and;
- the legend of the third degree.

These four items are usually considered to be the “real” Masonic secrets. But we should all realize that any interested party can go to the public library or bookstore and obtain books which reveal all these things. Clearly we cannot consider these to be secrets in the true sense of the word. There is no way we can keep these books from the public. What then is the meaning of our obligation to secrecy?

### **Our Obligation to Secrecy**

The obligations of Masonry, as well as all other teachings and laws of our Craft, are not things that Masons impose upon other

people. These obligations, teachings, and laws are things that each Mason agrees to accept for himself and to apply to himself. Thus when we agree to keep a Masonic secret we only agree that we will not discuss that matter with a non-mason. This agreement is then binding upon the Mason, but it is not and cannot be binding upon a non-mason.

Masons should not be disturbed by this. If a non-mason learns what he considers to be our secrets, we are under no obligation to take action of any kind. But if the same person comes to us and asks us to affirm or deny that certain things are our secrets, then we must neither confirm nor deny what they have learned. We are best advised to simply change the subject. If that fails, then let the person read this page.

## **CHAPTER IV**

### **SECOND DEGREE**

Masonry is a progressive science, and is divided into different classes or degrees, for the more regular advancement in the knowledge of its mysteries. According to the progress we make, we limit or extend our inquiries; and in proportion to our capacity, we attain to a less or greater degree of perfection.

Masonry includes within its circle almost every branch of polite learning. Under the veil of its mysteries is comprehended a regular system of science. Many of its illustrations, to the confined genius, may appear unimportant; but the man of more enlarged faculties will perceive them to be in the highest degree, useful and interesting.

The first degree is well calculated to enforce the duties of morality, and imprint on the memory the noblest principles which can adorn the human mind. It is, therefore, the best introduction to the second degree, which not only extends the same plan, but comprehends a more diffusive system of knowledge. Here practice and theory join, in qualifying the industrious Mason to share the pleasures which an advancement in the art must necessarily afford. Listening with attention to the wise opinions of experienced Craftsmen on important subjects, he gradually familiarizes his mind to useful instruction, and is soon enabled to investigate truths of the utmost concern in the general transactions of life.

#### **FIRST SECTION**

A knowledge of the work of this degree is absolutely necessary for all Craftsmen, and as the work contains the Ceremony of Passing and many other important particulars, no officer or member of a Lodge should be unacquainted with it.

Here he is entrusted with particular tests, to enable him to prove his title to the privileges of this degree, while satisfactory reasons

are given for their origin. Many duties, which cement in the firmest union well informed brethren, are illustrated in this section; and an opportunity is given to make such advances in Masonry, as will always distinguish the abilities of those who have arrived at preferment.

### **Amos VII, 7, 8**

- Thus he showed me:
- and behold, the Lord stood upon a wall made by a plumb-line,
- with a plumb-line in his hand.
- And the Lord said unto me, Amos, what seest thou? And I said, a plumb-line.
- Then said the Lord, Behold, I will set a plumb-line in the midst of my people, Israel:
- I will not again pass by them any more.

(Paraphrase of the above for music:)

Air: **Missionary Hymn or Hankey 76.76.D.**

(See Chapter XV for music and words)

His laws inspire our being  
Our light is from his Sun;  
Beneath the Eye All-seeing  
Our Mason's work is done.  
His plumb-line, in uprightness,  
Our faithful guide shall be,  
And in the Source of brightness  
Our willing eyes shall see.  
Thou, Father, art the Giver  
To every earnest prayer—  
Oh, be the Guide forever  
To this our brother dear!  
.By law and precept holy,  
By token, word and sign,

Exalt him, now so lowly,  
    Upon this grand design.  
Within thy chamber name him  
    A workman wise and true—  
While loving Crafts shall claim him  
    In bonds of friendship due;  
Thus shall these walls extol thee,  
    And future ages prove  
What Masons joy to call thee—  
    The God of Truth and Love.

The Plumb, Square, and Level, those noble and useful implements of a Fellow Craft, are here introduced and moralized, and serve as a constant admonition to the practice of virtue and morality.

The PLUMB is an instrument made use of by Operative Masons, to raise perpendiculars, the SQUARE, to square their work, and the LEVEL, to lay horizontals; but we, as Free and Accepted Masons, are taught to make use of them for more noble and glorious purposes. The Plumb admonishes us to walk uprightly in our several stations before God and man, squaring our actions by the Square of virtue, and remembering that we are traveling upon the Level of time, to “that undiscovered country, from whose bourn no traveler returns.”

The second part of the work of this degree has recourse to the origin of the Institution, and views Masonry under two denominations, operative and speculative. These are separately considered, and the principles on which both are founded, particularly explained. Their affinity is pointed out by allegorical figures, and typical representations. The period stipulated for rewarding merit is fixed, and the inimitable moral to which that circumstance alludes is explained. The creation of the world is described, and many particulars recited, all of which have been carefully preserved among Masons, and transmitted from one age to another, by oral tradition. Circumstances of great importance to the Fraternity are here

particularized and many traditional tenets and customs confirmed by sacred and profane record. The celestial and terrestrial globes are considered; and here the accomplished gentleman may display his talents to advantage in the elucidation of the Orders of Architecture, the Senses of human nature, and the liberal Arts and Sciences, which are severally classed in a regular arrangement. In short, the section contains a store of valuable knowledge, founded on reason and sacred record, both entertaining and instructive. Masonry is considered under two denominations: Operative and Speculative.

### **OPERATIVE MASONRY**

By OPERATIVE MASONRY we allude to a proper application of the useful rules of architecture, whence a structure will derive figure, strength and beauty, and whence will result a due proportion, and a just correspondence in all its parts. It furnishes us with dwellings, and convenient shelter from the vicissitudes and inclemencies of the seasons; and while it displays the effects of human wisdom, as well in the choice, as in the arrangement of the sundry materials of which an edifice is composed, it demonstrates that a fund of science and industry is implanted in man for the best, most salutary and beneficent purposes.

### **SPECULATIVE MASONRY**

By SPECULATIVE MASONRY, we learn to subdue the passions, act upon the square, keep a tongue of good report, maintain secrecy, and practice charity. It is so far interwoven with religion, as to lay us under obligations to pay that rational homage to the Deity, which at once constitutes our duty and our happiness. It leads the contemplative to view with reverence and admiration the glorious works of the creation, and inspires him with the most exalted ideas of the perfections of his Divine Creator. • • •

In six days God created the heavens and the earth, and rested upon the seventh day. The seventh, therefore, our ancient brethren

consecrated as a day of rest from their labors, thereby enjoying frequent opportunities to contemplate the glorious works of the creation, and to adore their great Creator. • • •

The doctrine of the spheres is included in the science of astronomy, and particularly considered in this section.

### **OF THE GLOBES**

The GLOBES are two artificial spherical bodies on the convex surface of which are represented the countries, seas, and various parts of the earth, the face of the heavens, the planetary revolutions, and other particulars.

The Sphere, with the parts of the earth delineated on its surface, is called the Terrestrial Globe; and that with the constellations, and other heavenly bodies, the Celestial Globe.

The principal use of the globes, besides serving as maps to distinguish the outward parts of the earth, and the situation of the fixed stars, is to illustrate and explain the phenomena arising from the annual revolution, and the diurnal rotation, of the earth round its own axis. They are the noblest instruments for improving the mind, and giving it the most distinct idea of any problem or proposition, as well as enabling it to solve the same. Contemplating these bodies, we are inspired with a due reverence for the Deity and His Works, and are induced to encourage the studies of astronomy, geography, navigation, and the arts dependent on them, by which society has been so much benefited.

### **OF ORDER IN ARCHITECTURE**

The orders of architecture come under consideration in this section; a brief description of them may therefore not be improper.

By order in architecture, is meant a system of all the members, proportions and ornaments of columns, and pilasters; or, it is a regular arrangement of the projecting parts of a building, which,



united with those of a column, form a beautiful, perfect and complete whole.

### OF ITS ANTIQUITY

From the first formation of society, order in architecture may be traced. When the rigor of seasons obliged men to contrive shelter from the inclemency of the weather, we learn that they first planted trees on end, and then laid others across, to support a covering. The bands which connected those trees at the top and bottom, are said to have given rise to the idea of the base and capital of pillars; and from this simple hint originally proceeded the more improved art of architecture.

The five orders are thus classed: The Tuscan, Doric, Ionic, Corinthian, and Composite.

The TUSCAN is the most simple and solid of the five orders. It was invented in Tuscany, whence it derived its name. Its column is seven diameters high; and its capital, base and entablature have but few mouldings. The simplicity of the construction of this column renders it eligible where ornament would be superfluous.

The DORIC, which is plain and natural, is the most ancient, and was invented by the Greeks. Its column is eight diameters high; and has seldom any ornaments on base or capital, except mouldings; though the frieze is distinguished by triglyphs and metopes, and triglyphs compose the ornaments of the frieze. The solid composition of this order gives it a preference in structures where strength and a noble simplicity are chiefly required.

The Doric is the best proportioned of all the orders. The several parts of which it is composed are founded on the natural position of solid bodies. In its first invention it was more simple than in its present state. In after times, when it began to be adorned, it gained the name of Doric; for when it was constructed in its primitive and simple form, the name of Tuscan was conferred on it. Hence the Tuscan precedes the Doric in rank, on account of its resemblance to that pillar in its original state.

The IONIC bears a kind of mean proportion between the more solid and delicate orders. Its column is nine diameters high; its capital is adorned with volutes, and its cornice has dentils. There is both delicacy and ingenuity displayed in this pillar, the invention of which is attributed to the Ionians, as the famous temple of Diana, at Ephesus, was of this order. It is said to have been formed after the model of an agreeable young woman, of an elegant shape, dressed in her hair, as a contrast to the Doric order, which was formed after that of a strong, robust man.

The CORINTHIAN, the richest of the five orders, is deemed a masterpiece of art. Its column is ten diameters high, and its capital is adorned with two rows of leaves, and eight volutes, which sustain the abacus. The frieze is ornamented with curious devices, the cornice with dentils and modillions. This order is used in stately and superb structures.

It was invented at Corinth, by Callimachus, who is said to have taken the hint of the capital of this pillar from the following remarkable circumstance: Accidentally passing by the tomb of a young lady, he perceived a basket of toys, covered with a tile, placed over an acanthus root, having been left there by her nurse. As the branches grew up, they encompassed the basket, till, arriving at the tile, they met with an obstruction, and bent downward. Callimachus, struck with the object, set about imitating the figure; the vase of the capital he made to represent the basket; the abacus the tile; and the volutes the bending leaves.

The COMPOSITE is compounded of the other orders, and was contrived by the Romans. Its capital has the two rows of leaves of the Corinthian, and the volutes of the Ionic. Its column has the quarterround as the Tuscan and Doric order, is ten diameters high, and its cornice has dentils or simple modillions. This pillar is generally found in buildings where strength, elegance, and beauty are displayed.

## **OF THE INVENTION OF ORDER IN ARCHITECTURE**

The ancient and original orders of architecture, revered by Masons, are no more than three, the Doric, Ionic, and Corinthian, which were invented by the Greeks. To these the Romans have added two: the Tuscan, which they made plainer than the Doric; and the Composite, which was more ornamental, if not more beautiful, than the Corinthian. The first three orders alone, however, show invention and particular character, and essentially differ from each other; the two others have nothing but what is borrowed, and differ only accidentally; the Tuscan is the Doric in its earliest state; and the Composite is the Corinthian enriched with the Ionic. To the Greeks, therefore, and not to the Romans, we are indebted for what is great, judicious and distinct in architecture.

## **OF THE FIVE SENSES OF HUMAN NATURE**

An analysis of the human faculties is next given in this section, in which the five external senses of human nature particularly claim attention. These are Hearing, Seeing, Feeling, Smelling, and Tasting.

**HEARING** is that sense by which we distinguish sounds, and are capable of enjoying all the agreeable charms of music. By it we are enabled to enjoy the pleasures of society, and reciprocally to communicate to each other our thoughts and intentions, our purposes and desires; while thus our reason is capable of exerting its utmost power and energy.

The wise and beneficent Author of Nature intended, by the formation of this sense, that we should be social creatures, and receive the greatest and most important part of our knowledge by the information of others. For these purposes we are endowed with hearing, that, by a proper exertion of our natural powers, our happiness may be complete.

**SEEING** is that sense by which we distinguish objects, and in an instant of time, without change of place or situation view armies in

battle array, figures of the most stately structures, and all the agreeable variety displayed in the landscape of nature. By this sense we find our way in the pathless ocean, traverse the globe of earth, determine its figure and dimensions, and delineate any region or quarter of it. By it we measure the planetary orbs, and make new discoveries in the sphere of the fixed stars. Nay, more: by it we perceive the tempers and dispositions, the passions and affections, of our fellow creatures, when they wish most to conceal them; so that, though the tongue may be taught to lie and dissemble, the countenance would display hypocrisy to the discerning eye. In fine, the rays of light which administer to this sense, are the most astonishing parts of the animated creation, and render the eye a peculiar object of admiration.

Of all the faculties, sight is the noblest. The structure of the eye, and its appurtenances, evinces the admirable contrivance of nature for performing all its various external and internal motions; while the variety displayed in the eyes of different animals suited to their several ways of life, clearly demonstrates this organ to be the masterpiece of nature's work.

FEELING is that sense by which we distinguish the different qualities of bodies; such as heat and cold, hardness and softness, roughness and smoothness, figure, solidity, motion and extension.

These three senses,—Hearing, Seeing, and Feeling,—are deemed peculiarly essential among Masons.

SMELLING is that sense by which we distinguish odors, the various kinds of which convey different impressions to the mind. Animal and vegetable bodies, and indeed most other bodies, while exposed to the air, continually send forth effluvia of vast subtlety, as well in the state of life and growth as in the state of fermentation and putrefaction. These effluvia, being drawn into the nostrils along with the air, are the means by which all bodies are smelled. Hence it is evident, that there is a manifest appearance of design in the great Creator's having planted the organ of smell in the inside of that canal, through which the air continually passes in respiration.

TASTING enables us to make a proper distinction in the choice of our food. The organ of this sense guards the entrance of the alimentary canal as that of smelling guards the entrance of the canal for respiration. From the situation of both these organs, it is plain that they were intended by nature to distinguish wholesome food from that which is nauseous. Everything that enters into the stomach must undergo the scrutiny of tasting; and by it we are capable of discerning the changes which the same body undergoes in the different compositions of art, cookery, chemistry, pharmacy, etc.

Smelling and tasting are inseparably connected, and it is by the unnatural kind of life men commonly lead in society, that these senses are rendered less fit to perform their natural offices.

On the mind all our knowledge must depend; what, therefore, can be a more proper subject for the investigation of Masons? By anatomical dissection and observation, we become acquainted with the body; but it is by the anatomy of the mind alone we discover its powers and principles.

To sum up the whole of this transcendent measure of God's bounty to man, we shall add, that memory, imagination, taste, reasoning, moral perception, and all the active powers of the soul, present a vast and boundless field for philosophical disquisition, which far exceed human inquiry, and are peculiar mysteries, known only to nature, and to nature's God, to whom we are all indebted for creation, preservation and every blessing we enjoy.

### **OF THE SEVEN LIBERAL ARTS AND SCIENCES**

The seven liberal Arts and Sciences, Grammar, Rhetoric, Logic, Arithmetic, Geometry, Music and Astronomy, are next illustrated in this section; it may not, therefore, be improper to insert here a short explanation of them.

GRAMMAR teaches the proper arrangement of words, according to the idiom or dialect of any particular people; and that excel-

lency of pronunciation, which enables us to speak or write a language with accuracy, agreeably to reason and correct usage.

RHETORIC teaches us to speak copiously and fluently on any subject, not merely with propriety alone, but with all the advantages of force and elegance; wisely contriving to captivate the hearer by strength of argument and beauty of expression, whether it be to entreat and exhort, to admonish or applaud.

LOGIC teaches us to guide our reason discretionally in the general knowledge of things, and directs our inquiries after truth. It consists of a regular train of argument, whence we infer, deduce, and conclude, according to certain premises laid down, admitted, or granted; and in it are employed the faculties of conceiving, judging, reasoning, and disposing; all of which are naturally led on from one gradation to another, till the point in question is finally determined.

ARITHMETIC teaches the powers and properties of numbers, which is variously effected by letters, tables, figures and instruments. By this art, reasons and demonstrations are given, for finding out any certain number, whose relation or affinity to another is already known or discovered.

GEOMETRY treats of the powers and properties of magnitudes in general, where length, breadth, and thickness are considered, from a point to a line, from a line to a superficies, and from a superficies to a solid. A point is a dimensionless figure; or an indivisible part of space. A line is a point continued, and a figure of one capacity, namely, length. A superficies is a figure of two dimensions, namely, length and breadth. A solid is a figure of three dimensions, namely length, breadth and thickness.

By this science, the architect is enabled to construct his plans, and execute his designs; the general to arrange his soldiers; the engineer to mark out ground for encampments; the geographer to give us the dimensions of the world, and all things therein contained, to

delineate the extent of seas, and specify the divisions of empires, kingdoms and provinces. By it, also, the astronomer is enabled to make his observations and to fix the durations of times and seasons, years and cycles. In fine, geometry is the foundation of architecture, and the root of the mathematics.

MUSIC teaches the art of forming concords, so as compose delightful harmony, by a mathematical and proportional arrangement of acute, grave and mixed sounds. This art, by a series of experiments, is reduced to a demonstrative science, with respect to tones, and the intervals of sound. It inquires into the nature of concords and discords, and enables us to find out the proportion between them by numbers.

ASTRONOMY is that divine art, by which we are taught to read the wisdom, strength and beauty of the Almighty Creator, in those sacred pages, the celestial hemisphere. Assisted by astronomy, we can observe the motions, measure the distances, comprehend the magnitudes, and calculate the periods and eclipses, of the heavenly bodies. By it we learn the use of the globes, the system of the world, and the preliminary law of nature. While we are employed in the study of this science, we must perceive unparalleled instances of wisdom and goodness, and, through the whole creation, trace the glorious Author by his works.

### **OF THE MORAL ADVANTAGES OF GEOMETRY**

From this theme we proceed to illustrate the moral advantages of Geometry, a subject on which the following observations may not be unacceptable

GEOMETRY, the first and noblest of sciences, is the basis on which the superstructure of Masonry is erected. By geometry, we may curiously trace nature, through her various windings, to her most concealed recesses, By it, we discover the power, the wisdom, and the goodness of the Grand Artificer of the Universe, and view with

delight the proportions which connect this vast machine. By it we discover how the planets move in their different orbits and demonstrate their various revolutions. By it we account for the return of seasons, and the variety of scenes which each season displays to the discerning eye. Numberless worlds are around us, all framed by the same Divine artist, which roll through the vast expanse, and are all conducted by the same unerring law of nature.

A survey of nature, and the observations of her beautiful proportions, first determined man to imitate the Divine plan, and study symmetry and order. This gave rise to societies, and birth to every useful art. The architect began to design, and the plans, which he laid down, being improved by experience and time, have produced works which are the admiration of every age.

The lapse of time, the ruthless hand of ignorance, and the devastations of war, have laid waste and destroyed many valuable monuments of antiquity, on which the utmost exertions of human genius have been employed. Even the Temple of Solomon, so spacious and magnificent, and constructed by so many celebrated artists, escaped not the unsparing ravages of barbarous force. Freemasonry, notwithstanding, has still survived. The attentive ear receives the sound from the instructive tongue, and the mysteries of Masonry are safely lodged in the repository of faithful breasts. Tools and implements of architecture are selected by the Fraternity, to imprint on the memory wise and serious truths; and thus, through a succession of ages, are transmitted unimpaired, the excellent tenets of our Institution.



## **CHARGE AT PASSING**

BROTHER, being advanced to the second degree of Masonry, we congratulate you on your preferment. The internal, and not the external qualifications of a man, are what Masonry regards. As you increase in knowledge, you will improve in social intercourse.

It is unnecessary to recapitulate the duties which, as a Mason, you are bound to discharge; or enlarge on the necessity of a strict adherence to them, as your own experience must have established their value.

Our laws and regulations you are strenuously to support; and be always ready to assist in seeing them duly executed. You are not to palliate, or aggravate, the offenses of your brethren; but, in the decision of every trespass against our rules, you are to judge with candor, admonish with friendship, and reprehend with justice.

The study of the liberal arts, that valuable branch of education, which tends so effectually to polish and adorn the mind, is earnestly recommended to your consideration; especially the science of geometry, which is established as the basis of our art. Geometry, or Masonry, originally synonymous terms, being of a divine and moral nature, is enriched with the most useful knowledge; while it proves the wonderful properties of nature, it demonstrates the more important truths of morality.

Your past behavior and regular deportment have merited the honor which we have now conferred; and in your new character it is expected that you will conform to the principles of the Fraternity, by steadily persevering in the practice of every commendable virtue. Such is the nature of your engagements as a Fellow Craft, and to these duties you are bound by the most sacred ties.

## **SECOND SECTION**

The second section of the degree consists of a lecture in two parts. (Second Section of the Fellowcraft Degree Lecture was made an optional lecture by vote of Grand Lodge Assembly in 1997)

## CHAPTER V

### THIRD DEGREE

From this class the rulers of regular Bodies of Ancient Craft Masonry are selected; as it is only from those, who are capable of giving instruction, that we can properly expect to receive it.

#### FIRST SECTION

The ceremony of initiation into the third degree is contained in this section of the degree and here many other useful instructions are given.

The following passage of Scripture is introduced during the ceremonies:

#### ECCLESIASTES XII, 1-7

- Remember now thy Creator in the days of thy youth, while the evil days come not, nor the years draw nigh, when thou shalt say, I have no pleasure in them;
- while the sun, or the light, or the moon, or the stars, be not darkened, nor the clouds return after the rain:
- in the day when the keepers of the house shall tremble, and the strong men shall bow themselves,
- • and the grinders cease because they are few, and those that look out of the windows be darkened, and the doors shall be shut in the streets,
- • when the sound of the grinding is low, and he shall rise up at the voice of the bird, and all the daughters of music shall be brought low;
- • also when they shall be afraid of that which is high, and fears shall be in the way,
- • • and the almond tree shall flourish, and the grasshopper shall be a burden, and desire shall fail:
- • • because man goeth to his long home, and the mourners go about the streets: or ever the silver cord be loosed, or the golden bowl be broken, or the pitcher be broken at the fountain, or the wheel broken at the cistern.
- • • Then shall the dust return to the earth as it was: and the spirit shall return unto God who gave it.

Paraphrase of the above for Music.  
Air: **Bonny Doon or Sweet Hour LMD**  
(See Chapter XV for music and words)

Let us remember in our youth,  
    Before the evil days draw nigh,  
Our Great Creator, and his Truth,  
    Ere memory fail, and pleasures fly;  
Or sun or moon, or planets light  
    Grow dark, or clouds return in gloom;  
Ere vital spark no more incite;  
    When strength shall bow and years consume.  
Let us in youth remember Him!  
    Who formed our frame, and spirits gave  
Ere windows of the mind grow dim,  
    Or door of speech obstructed wave;  
When voice of bird fresh terror wake,  
    And music's daughters charm no more,  
Or fear to rise, with trembling shake,  
    Along the path we travel o'er.  
In youth to God let memory cling,  
    Before desire shall fail or wane  
Or e'er be loosed life's silver string  
    Or bowl at fountain rent in twain;  
For man to his long home doth go,  
    And mourners group around his urn!  
Our dust to dust again must flow,  
    And spirits unto God return.

The working tools of a Master Mason, which are illustrated in this section, are all the implements of Masonry indiscriminately, but more especially the Trowel.

The TROWEL is an instrument made use of by operative Masons, to spread the cement which unites a building into one common mass; but we, as Free and Accepted Masons, are taught to make use of it for the more noble and glorious purpose of spreading the cement of Brotherly Love and affection, that cement which

unites us into one sacred band, or society of friends and brothers, among whom no contention should ever exist, but that noble contention, or rather emulation, of who best can work, or best agree.

## SECOND SECTION

This section recites the historical traditions of the Fraternity and presents to view a finished picture of the utmost consequence to the Fraternity. It exemplifies an instance of virtue, fortitude, and integrity, seldom equaled, and never excelled, in the history of man.

### Air: Pleyel's Hymn

(See Chapter XV for music and words)

Solemn strikes the funeral chime!  
Notes of our departing time,  
As we journey here below,  
Through a pilgrimage of woe!  
Mortals, now indulge a tear,  
For mortality is here!  
See how wide her trophies wave,  
O'er the slumbers of the grave!  
Here another guest we bring,  
Seraphs of celestial wing,  
To our funeral altar come,  
Waft a friend and brother home.  
Lord of all! below—above—  
Fill our hearts with Truth and Love.  
As dissolves our earthly tie,  
Take us to thy Lodge on high.

## PRAYER AT RAISING

(Job xiv)

Thou, O God! knowest our down-sitting and our uprising, and understandest our thought afar off. Shield and defend us from the evil intentions of our enemies, and support us under the trials and afflic-

tions we are destined to endure, while traveling through this vale of tears. Man that is born of a woman, is of few days and full of trouble. He cometh forth as a flower, and is cut down; he fleeth also as a shadow, and continueth not. Seeing his days are determined, the number of his months are with Thee; Thou hast appointed his bounds that he cannot pass; turn from him, that he may rest, till he shall accomplish his day. For there is hope of a tree, if it be cut down, that it will sprout again, and that the tender branch thereof will not cease. But man dieth and wasteth away; yea, man giveth up the ghost, and where is he? As the waters fail from the sea, and the flood decayeth and drieth up: so man lieth down, and riseth not up till the heavens shall be no more. Yet, O Lord! have compassion on the children of Thy creation, administer them comfort in time of trouble, and save them with an everlasting salvation.—Amen.

**Response:** So mote it be.

### **CHARGE AT RAISING**

**BROTHER**, your zeal for the institution of Masonry, the progress you have made in the mystery, and your conformity to our regulations, have pointed you out as a proper object of our favor and esteem.

You are now bound by duty, honor and gratitude, to be faithful to your trust; to support the dignity of your character on every occasion; and to enforce, by precept and example, obedience to the tenets of the Fraternity.

In the character of a Master Mason, you are authorized to correct the errors and irregularities of your uninformed brethren, and to guard them against a breach of fidelity. To preserve the reputation of the Fraternity unsullied, must be your constant care; and for this purpose it is your province to recommend to your inferiors, obedience and submission; to your equals, courtesy and affability; to your superiors, kindness and condescension. Universal benevolence you are always to inculcate; and, by the regularity of your own behavior,

afford the best example for the conduct of others less informed. The Ancient Landmarks, intrusted to your care, you are carefully to preserve; and never suffer them to be infringed, or countenance a deviation from the established usages and customs of the Fraternity.

Your virtue, honor, and reputation, are concerned in supporting with dignity the character you now bear. Let no motive, therefore, make you swerve from your duty, violate your vows or betray your trust; but be true and faithful, and imitate the example of that celebrated artist whom you this evening represent. Thus you will render yourself deserving of the honor which we have conferred, and merit the confidence that we have reposed.

### **THIRD SECTION**

This section also illustrates certain hieroglyphical emblems and inculcates many useful lessons, to extend knowledge and promote virtue.

In this lecture, many particulars relative to King Solomon's Temple are considered.

The construction of this grand edifice was attended with two remarkable circumstances. From Josephus we learn, that, although seven years were occupied in building it, yet during the whole term it rained not in the day time, that the workmen might not be obstructed in their labor; and from the sacred history it appears, that there was neither the sound of the hammer, nor axe, nor any tool of iron, heard in the house, while it was building.

This famous Temple was supported by fourteen hundred and fifty-three columns, and two thousand nine hundred and six pilasters; all hewn from the finest Parian marble. There were employed in its building, three Grand Masters; three thousand and three hundred Masters, or overseers of the work; eighty thousand Fellow-Crafts • and seventy thousand Entered Apprentices, or bearers of burdens. All these were classed and arranged in such a manner by the wisdom of King Solomon, that neither envy, discord nor confusion

were suffered to interrupt that universal peace and tranquility, which pervaded the world at this important period.

The THREE STEPS, usually delineated on the Master's Carpet, are emblematical of the three principal stages of human life, viz.: Youth, Manhood and Age. In YOUTH, as Entered Apprentices, we ought industriously to occupy our minds in the attainment of useful knowledge; in MANHOOD, as Fellow-Crafts, we should apply our knowledge to the discharge of our respective duties to God, our neighbors, and ourselves; that so in AGE, as Master Masons, we may enjoy the happy reflections consequent on a well-spent life, and die in the hope of a glorious immortality.

The POT OF INCENSE is an emblem of a pure heart, which is always an acceptable sacrifice to the Deity; and, as this glows with fervent heat, so should our hearts continually glow with gratitude to the great and beneficent Author of our existence, for the manifold blessings and comforts we enjoy.

The BEE HIVE is an emblem of industry, and recommends the practice of that virtue to all created beings, from the highest seraph in heaven, to the lowest reptile of the dust. It teaches us, that as we came into the world rational and intelligent beings, so we should ever be industrious ones; never sitting down contented while our fellow-creatures around us are in want, when it is in our power to relieve them, without inconvenience to ourselves.

When we take a survey of nature, we view man, in his infancy, more helpless and indigent than the brutal creation; he lies languishing for days, months and years, totally incapable of providing sustenance for himself, of guarding against the attack of the wild beasts of the field, or sheltering himself from the inclemencies of the weather.

It might have pleased the great Creator of heaven and earth to have made man independent of all other beings; but, as dependence

is one of the strongest bonds of society, mankind were made dependent on each other for protection and security, as they thereby enjoy better opportunities of fulfilling the duties of reciprocal love and friendship. Thus was man formed for social and active life, the noblest part of the work of God; and he that will so demean himself as not to be endeavoring to add to the common stock of knowledge and understanding, may be deemed a drone in the hive of nature, a useless member of society, and unworthy of our protection as Masons.

The BOOK OF CONSTITUTIONS, guarded by the Tyler's sword, reminds us that we should be ever watchful and guarded in our thoughts, words and actions, particularly when before the enemies of Masonry, ever bearing in remembrance those truly Masonic virtues, silence and circumspection.

The SWORD, pointing to a naked heart, demonstrates that justice will sooner or later overtake us; and although our thoughts, words, and actions, may be hidden from the eyes of man, yet that All-Seeing Eye, whom the Sun, Moon and Stars obey, and under whose watchful care even Comets perform their stupendous revolutions, pervades the inmost recesses of the human heart, and will reward us according to our merits.

The ANCHOR AND ARK are emblems of a well-grounded hope, and a well-spent life. They are emblematical of that divine ark which safely wafts us over this tempestuous sea of troubles, and that anchor which shall safely moor us in a peaceful harbor, where the wicked cease from troubling, and the weary shall find rest.

The FORTY-SEVENTH PROBLEM OF EUCLID. This was an invention of our ancient friend and brother, the great Pythagoras, who, in his travels through Asia, Africa, and Europe, was initiated into several orders of priesthood, and raised to the sublime degree of a



Master Mason. This wise philosopher enriched his mind abundantly in a general knowledge of things, and more especially in Geometry or Masonry; on this subject he drew out many problems and theorems, and among the most distinguished, he erected this, which in the joy of his heart, he called Eureka, in the Grecian language signifying, I have found it; and upon the discovery of which, he is said to have sacrificed a hecatomb. It teaches Masons to be general lovers of the arts and sciences.

The HOUR-GLASS is an emblem of human life Behold! how swiftly the sands run, and how rapidly our lives are drawing to a close. We cannot, without astonishment, behold the little particles which are contained in this machine, how they pass away almost imperceptibly, and yet, to our surprise, in the short space of an hour, they are all exhausted. Thus wastes man! Today he puts forth the tender leaves of hope; tomorrow, blossoms, and bears his blushing honors thick upon him; the next day comes a frost which nips the shoot, and when he thinks his greatness is still aspiring, he falls, like autumn leaves, to enrich our mother earth.

The SCYTHE is an emblem of time, which cuts the brittle thread of life, and launches us into eternity. Behold! what havoc the scythe of time makes among the human race; if by chance we should escape the numerous evils incident to childhood and youth, and with health and vigor arrive to the years of manhood, yet withal we must soon be cut down by the all-devouring scythe of time, and be gathered into the land where our fathers have gone before us.

## CHAPTER VI

### INSTALLATION OF LODGE OFFICERS

No brother, elected or appointed to office, in a chartered Lodge can enter upon the discharge of his duties until installed. The officers of the Lodge under dispensation cannot be installed, and therefore acquire no rank by such service. The officers of a newly constituted Lodge are installed by the Grand Master or his proxy, and he may at pleasure, install the officers of any Lodge. With this exception, it is the right and duty of every Master to install, or have installed, his successor, either on the evening of election, or on or before the next stated meeting. Any Past Master, in good standing, of a chartered Lodge, is authorized to install a Master-elect. Then, assisted by a brother, usually a Past Master, acting as Marshal, the installation service proceeds.

When the Master is installed, he has the right to install the other officers, except at the constitution of a new Lodge, or when the Grand Master or his proxy may officiate. He usually waives this right, and requests the brother who installed him to proceed. No officer can be installed by proxy, hence an absentee must be installed by the Master at a subsequent meeting. If an objection is made to the installation of the Master, and the Installing Officer deems the same sufficient, he postpones the services until the Grand Master decides what to do. If objection is made to any other elected brother, the installation proceeds, except as to his office. An installed officer hold his office until his successor is installed, but if re-elected, he must be re-installed. Public installations are permitted.

If such public installation is held in the hall, the Lodge is formally opened on the third degree, after which the families and friends of the brethren are admitted, or the Lodge may be opened in an adjoin-

ing apartment. The exercises may be made more interesting by the use of vocal and instrumental music.

The following service is intended for the annual installation of Lodge officers, where the same brother officiates throughout, but may be used at any installation. It is also intended for use at the installation of the officers of a new Lodge, with such variation of language, as may be necessary to fit the occasion. If the Grand Master or other officer of high rank officiates, he will be addressed by his proper Grand or other title.

The knocks of the gavel are never to be used in public.

## ANNUAL INSTALLATION

(The Marshal will see that the officers' jewels, the Deacons' and Stewards' rods, the Tyler's sword, the Book of Constitutions, the Charter, and the Lodge By-Laws are within reach, and so arranged that he can promptly hand them to the Installing Officer when required.)

The INSTALLING OFFICER takes the East, and says:)

Brethren of \_\_\_\_\_ Lodge, No \_\_\_\_\_, we are about to install your officers for the ensuing year.

Brother Secretary, announce the names of the officers-elect.

(The Secretary does so.)

Installing Officer. - Brethren, you have heard the names of the officers-elect. If any of you know aught, why any of them should not be installed, let him speak now, or forever after be silent.

(After waiting a few moments and hearing no objections, he proceeds:)

Hearing no objection, I will proceed.

Brother Marshal, present the Master-elect to the East.

**Marshal.** - Worshipful Master, I present Brother \_\_\_\_\_ to be installed Master of this Lodge. He is of good morals and of

great skill, true and trusty; and as he is a lover of our Fraternity, I doubt not that he will discharge the duties devolving upon him with fidelity.

**Installing Officer.-** (Calls up Lodge and says:) Let us pray.

### **PRAYER**

Most Holy and Gracious Lord God! We approach Thee with reverence, and implore Thy blessing on this brother, elected to preside over this Lodge. Fill his heart with thy love, that his tongue and actions may pronounce thy glory. Make him steadfast in thy service; grant him firmness of mind; animate his heart and strengthen his endeavors. May he teach thy judgments and thy laws, and be a true and faithful servant. Bless him, O Lord, and bless the work of his hands. Hear thou our prayer. Forgive our transgressions, and, finally, receive us into the Celestial Lodge above, where Thou forever reigneth. Amen.

**Response:** So mote it be.

### **OR ANOTHER PRAYER**

Most Holy and Gracious Lord God! We approach You with reverence, and implore Your blessing on this brother, elected to preside over this Lodge. Fill his heart with Your love, that his tongue and actions may pronounce Your glory. Make him steadfast in Your service; grant him firmness of mind; animate his heart and strengthen his endeavors. May he teach Your judgments and Your laws, and be a true and faithful servant. Bless him, O Lord, and bless the work of his hands. Hear our prayer. Forgive our transgressions, and, finally, receive us into the Celestial Lodge above, where You forever reign. Amen.

**Response:** So mote it be.

**Installing Officer.-** My Brother, place your right hand over your heart and repeat after me your official obligation:

I solemnly promise, upon the honor of a Mason, that in the office of Master of this Lodge, I will, to the best of my ability, strictly

comply with the Constitution, Laws, Rules and Regulations of the Grand Lodge of Ancient Free and Accepted Masons of Minnesota, the By-Laws of this Lodge, and all other ancient Masonic usages, so far as the same shall come to my knowledge.

(The brethren are seated. The following address, preceding the fifteen charges may be used or omitted at discretion.)

**Installing Officer.-** My Brother, you are now to be installed Master of this Lodge, with powers and prerogatives which are well nigh absolute. The interests of your Lodge, for weal or woe, will be in your keeping, during your term of office. The good resolutions, which doubtless you have formed, not to abuse or pervert these powers, I would gladly strengthen by a word of admonition. The very consciousness of the possession of a great power will ever make a generous mind cautious and gentle in its exercise. To rule has been the lot of many, and requires neither strength of intellect nor soundness of judgment; to rule well has been the fortune of but few, and may well be the object of an honorable ambition. It is not by the strong arm, or the iron will that obedience and order, the chief requisites, are secured, but by holding the key to the hearts of men. To be Master of his Lodge is an honor to which any well-informed Master Mason may laudably aspire. The office is one of great antiquity, dignity and respect, but its incumbent, to rule well, should possess and practice several important requisites.

**As a Man,** he should be of approved integrity and irreproachable morals, free from the dominion of hasty temper and ill-governed passions; of good repute in the world, and, an example to his brethren, in practicing the cardinal virtues of Temperance, Fortitude, Prudence and Justice.

**As a Citizen,** he should be loyal to his government, obedient to its laws, prompt in the duties he owes to society, and a pattern of fidelity in all social and domestic relations.

**As a Mason,** he should cling to the old Landmarks, have a knowledge of the laws, language and literature of Freemasonry; be desirous to learn and apt to teach, accomplished in the work and lectures, prompt to aid and relieve, and ever mindful, that though elevated for a time above his fellows, he is elevated by them, and should cultivate everywhere and at all times, the Golden Tenets of Brotherly Love, Relief and Truth.

**As an officer,** he should remember, first of all, that he is an individual Mason, sharing in that respect a common lot with his brethren, and therefore be interested in the welfare of each and all. He should be neither unduly ostentatious nor overbearing. He should be accessible to all, and should cultivate the friendship and confidence of his associate officers. He should be willing to take counsel with his brethren, and ready to give it. He should be patient in investigation, deliberate in judgment, prompt in execution, forbearing with evil doers, and ready to reward good. He should be opposed to the restless spirit of innovation, watchful over the treasury, and devoid of favoritism and partiality.

Such are some of the most important qualifications which a Master should possess, and the errors he should avoid. It may be that most, if not all, of us, have failed to reach this standard, but it should be your purpose to reach it, and thus be a bright and shining example to brethren who shall come after you.

(The **INSTALLING OFFICER** then addresses him:)

My Brother, previous to your investiture it is necessary that you should signify your assent to those Ancient Charges and Regulations which point out the duty of a Master of a Lodge.

1. You agree to be a good man and true, and strictly to obey the moral law.

2. You agree to be a peaceable citizen, and cheerfully to conform to the laws of the country in which you reside.

3. You promise not to be concerned in plots and conspiracies against government, but patiently to submit to the decisions of the constituted authorities

4. You agree to pay a proper respect to the civil magistrate, to work diligently, live creditably, and act honorably by all men.

5. You agree to hold in veneration the original rulers and patrons of Freemasonry, and their regular successors, supreme and subordinate, according to their stations; and to submit to the awards and resolutions of your brethren when in Lodge convened, in every case consistent with the Constitutions of the Fraternity.

6. You agree to avoid private piques and quarrels, and to guard against intemperance and excess.

7. You agree to be cautious in carriage and behavior, courteous to your brethren, and faithful to your Lodge.

8. You promise to respect genuine brethren, and to discountenance impostors and all dissenters from the original plan of Masonry.

9. You agree to promote the general good of society, to cultivate the social virtues, and to propagate the knowledge of the mystic art.

10. You promise to pay homage to the Grand Master for the time being, and to his officers when duly installed; and strictly conform to every edict of the Grand Lodge, or General Assembly of Masons, that is not subversive of the principles and groundwork of Masonry.

11. You admit that it is not in the power of any man, or body of men, to make innovations in the body of Masonry.

12. You promise a regular attendance on the committees and communications of the Grand Lodge, on receiving proper notice; and to pay attention to all the duties of Masonry, on convenient occasions.

13. You admit that no new Lodge shall be formed without permission of the Grand Lodge; and that no countenance be given to any irregular Lodge or to any person clandestinely initiated therein, being contrary to the Ancient Charges of Freemasonry.

14. You admit that no person can be regularly made a Mason in, or admitted a member of, any regular Lodge, without previous notice, and due inquiry into his character.

15. You agree that no visitors shall be received into your Lodge without due examination, and producing proper vouchers of their having been initiated in a regular Lodge.

These are the Regulations of Free and Accepted Masons. Do you submit to these Charges, and promise to support these Regulations, as all Masters have done in all ages before you?

(The **Master-elect** answers:) I do.

My Brother, in consequence of your cheerful conformity to the Charges and Regulations of the Fraternity you are now to be installed Master of this Lodge, in full confidence of your care, skill, and capacity to govern the same. With pleasure I now invest you with this jewel of your office - the Square.

As the SQUARE is employed by Operative Masons to fit and adjust the stones of a building, that all its parts may properly agree, so you, as Master of this Lodge, are admonished by the symbolic meaning of the Square to preserve that moral deportment among the members of your Lodge which should always characterize good Masons, and to exert your authority to prevent ill-feeling or angry discussion arising, to impair the harmony of its meetings.

I now place in your care the furniture and implements of Masonry. The Holy Bible with the Square and Compass upon its open pages, is on the Altar, where it must always be when the Lodge is at Labor.

The HOLY WRITINGS, that Great Light in Masonry, will guide you to all truth; it will direct your paths to the temple of happiness, and point out to you the whole duty of man.

The SQUARE teaches us to regulate our actions by rule and line, and to harmonize our conduct by the principles of morality and virtue.

The COMPASS teaches us to limit our desires in every station, that, rising to eminence by merit, we may live respected, and die regretted.



The RULE directs, that we should punctually observe our duty; press forward in the path of virtue, and, neither inclining to the right nor to the left, in all our actions have eternity in view.

The LINE teaches the criterion of moral rectitude, to avoid dissimulation in conversation and action, and to direct our steps to the path which leads to immortality.

The BOOK OF CONSTITUTIONS you are to search at all times. Cause it to be read in your Lodge, that none may pretend ignorance of the excellent precepts it enjoins.

You now receive in charge this CHARTER, by the authority of which this Lodge is held. Without its presence you cannot open your Lodge. You are, therefore, to preserve it carefully, and transmit it safely to your successor.

You will also receive in charge the BY-LAWS of your Lodge, which you are to see carefully and punctually executed.

Lastly, I place in your hand this GAVEL, the emblem of your authority. (Explains its use except in public installations. There he will say “You have already been instructed in its use.”) Use it firmly, but not arbitrarily, to the end that peace and harmony may prevail among your brethren.

I now conduct you (clasps his hand) to the oriental chair, and cover you with that distinction which, in this Lodge, it is alone your privilege to wear. (Places a hat upon his head and says:) Call up the brethren. (The Master does so.)

I now hail you as Master of this Lodge.

Master, behold your brethren.

Brethren, behold your Master, and unite with me in giving him the Grand Honors.

(If the ceremonies are in public, the procession will be dispensed with, and it and the Ode may be omitted if time is limited. If private, the Marshal forms a procession of the brethren, who march in single file, three times around the hall, signifying their

respect and obedience by the usual distinctive signs in the several degrees; during or after which, the following Master's Installation Ode may be sung, or if preferred, the Installation Ode found in the Grand Lodge Installation service, which follows this.)

**Air: Balerma or Azmon CM**

(See Chapter XV for music and words to Azmon CM)

Behold, O, Master in the East,  
    What glories greet thee there;  
What floods of radiance earthward stream;  
    The sun is rising fair.  
Behold, O, Master, glorious arts  
    Were cradled in the East;  
Behold what sciences came forth  
    Man's waking mind to feast.  
O Master, in thy symbol'd East,  
    Seek wisdom from above.  
And spread the light which heaven shall send,  
    Within thy Lodge in love.

The new Master will seat the brethren, after which he may address the Lodge. He will then announce his appointed officers, will uncover, vacate the East for the time being, and hand the gavel to the Installing Officer [if the latter has been requested to complete the service], who will proceed with the installation.

Installing Officer. Brother Marshal, present the other officers-elect and appointed for obligation (Done.)

Installing Officer. You will each place your right hand over your heart, and repeat after me your official obligation:

I solemnly promise upon the honor of a Mason, that I will serve this Lodge in the office to which I have been elected, or appointed, and will perform all the duties pertaining thereto, to the best of my ability.

(They will then be seated, and will be presented severally by the Marshal in the order of their rank.)

Worshipful Master: I present to you Brother \_\_\_\_\_, to be installed as \_\_\_\_\_.

(As each officer is installed, he will be conducted to his station or place, during which there should be strains of instrumental march music, or the singing of an ode, or both. The Installing Officer will deliver the several charges as follows:)

### **TO SENIOR WARDEN**

My Brother, you have been elected Senior Warden of this Lodge, and I now invest you with this jewel of your office, – the Level.

The LEVEL demonstrates that we are descended from the same stock, partake of the same nature, and share the same hope; and, though distinctions among men are necessary to preserve subordination, yet no eminence of station should make us forget that we are brethren; because a time will come, and the wisest knows not how soon, when all distinction but that of goodness shall cease, and death, the grand leveler of human greatness, reduce us to the same state.

Your regular attendance on the meetings of the Lodge is essentially necessary. In the absence of the Master you are to govern this Lodge; in his presence you are to assist him in the government of it. I firmly rely on your knowledge of Masonry and attachment to the Lodge for the faithful discharge of the duties of this important trust. - Look well to the West.

(He is conducted to his station.)

Continue Ode. Air: **Balerma or Azmon CM**

(See Chapter XV for music and words to Azmon CM)

O, Warden, with thy Level poised,  
What lesson dost thou give?  
Are all men equal? Shall the worm  
On king and peasant live?  
O, Warden, where King Hiram stood,  
Like him, seek strength above;

Sustain the East, pay all their dues,  
Protect the weak in love.

(The Junior Warden is presented.)

### **TO JUNIOR WARDEN**

My Brother, you have been elected Junior Warden of this Lodge, and I now invest you with the jewel of your office,- the Plumb.

The PLUMB admonishes us to walk uprightly in our several stations, to hold the scale of justice in equal poise, to observe the just medium between intemperance and pleasure, and to make our passions and prejudices coincide with the line of duty. To you is committed the superintendence of the Craft during the hours of refreshment; it is, therefore, indispensably necessary that you should not only be temperate and discreet in the indulgence of your own inclinations, but carefully observe that none of the Craft be suffered to convert the purposes of refreshment into intemperance and excess.

Your regular and punctual attendance is particularly requested; and I have no doubt that you will faithfully execute the duty which you owe to your present position.- Look well to the South.

(He is conducted to his station.)

Continue Ode. Air: **Balerma or Azmon CM**

(See Chapter XV for music and words to Azmon CM)

O, Warden, with thy Plumb upraised,

What doth the emblem teach?

Do all the Craft uprightly walk,

And practice what they preach?

O, Warden, where the Faithful One

Observed the glorious sun

Like him adorn with Beauty still

The work by him begun.

(The Treasurer is presented.)

### **TO TREASURER**

My Brother, you have been elected Treasurer of this Lodge, and I now invest you with the jewel of your office.

It is your duty to receive all moneys from the hands of the Secretary, keep just and regular accounts of the same, and pay them out at the Worshipful Master's will and pleasure, with the consent of the Lodge.

I trust your regard for the Fraternity will prompt you to the faithful discharge of the duties of your office.

(He is conducted to his place, and the Secretary is presented.)

### **TO SECRETARY**

My Brother, you have been elected Secretary of this Lodge and I now invest you with the jewel of your office.

It is your duty to observe the Worshipful Master's will and pleasure, to record the proceedings of the Lodge; to receive all moneys and to pay them into the hands of the Treasurer.

Your good inclination to Masonry and this Lodge, I hope, will induce you to discharge the duties of your office with fidelity, and by so doing you will merit the esteem and applause of your brethren.

(He is conducted to his place, and the Lodge Education Officer is presented.)

### **TO LODGE EDUCATION OFFICER**

My Brother, you have been appointed as the Lodge Education Officer of this Lodge and I now invest you with the jewel of your office - the Lamp of Knowledge.

The LAMP OF KNOWLEDGE reminds us that no Mason can possess the philosophy or inculcate the tenets of Masonry without sound education and life-long learning. Knowledge must enlighten the mind and heart for the application of our ideals. You must help

to guide this Lodge toward the delightful light of knowledge and concern. By your assistance and encouragement, you will help the brothers of all degrees to study and enjoy Ancient Craft Masonry. Your coordination of monthly educational programs and activities will be cheerfully received and eagerly expected.

Your early and regular attendance upon the Communications of this Lodge, is necessary and expected, and I rely upon you to carefully meet this requirement.

(NOTE: Station of the Lodge Education Officer will be to the immediate left of the Worshipful Master in the East. He is conducted to his place, and the Deacons are presented.)

### **TO DEACONS**

Brethren, you are appointed Senior and Junior Deacons of this Lodge, and I now invest you with the jewels of your office, and place in your hands these **BLACK RODS**, which you will bear, in the performance of official duty, as symbols of your deputed authority.

It is your province to attend on the Master and Wardens, and to serve as their proxies in the active duties of the Lodge, such as the reception of candidates into the different degrees of Masonry, the introduction and accommodation of visitors, and in the immediate practice of our rites.

The **SQUARE AND COMPASS** as badges of your office are entrusted in your care, not doubting your vigilance and attention.

(They are conducted to their places, and the Chaplain is presented.)

### **TO CHAPLAIN**

My Brother, you are appointed Chaplain of this Lodge, and I invest you with this jewel. It is your special duty to conduct the devotions of the Lodge, and bear before the throne of Heavenly Grace the

spiritual needs of your brethren. In all your intercourse with them, it is expected that you will “point to Heaven and lead the way.”

(He is conducted to his place, and the Stewards are presented.)

### **TO STEWARDS**

Brethren, you are appointed Senior and Junior Stewards of this Lodge, and I now invest you with the jewels of your office, and place in your hands these WHITE RODS, which you will bear in the performance of your official duties.

It is your duty to assist the Deacons and other officers in the discharge of their duties, and to see that the tables are properly furnished at refreshment and that every brother is suitably provided for. It is also your duty to aid in the introduction of candidates, and as from you the first impression of our Institution is received by them, you should be particularly careful, by the seriousness of your deportment, to properly prepare them for the dignified and important ceremonies of initiation. Your regular and early attendance will afford the best proof of your zeal and attachment to the Lodge.

(They are conducted to their places, and the Marshal is presented.)

### **TO MARSHAL**

My Brother, you are appointed Marshal of this Lodge. I now invest you with the jewel of your office, and place in your hands this BATON, as the appropriate badge of your office. It is your duty to form and conduct processions of the Lodge on all public occasions, and to attend to such other interests in the practice of our rites, as the Master shall direct

(He is conducted to his place, and the Tyler is presented.)

## TO TYLER

My Brother, you have been appointed Tyler of this Lodge, and I now invest you with the jewel and the instrument of your office.

As the **SWORD** is placed in the hands of the Tyler to enable him effectually to guard against the approach of cowans and eavesdroppers, and suffer none to pass or repass but such as are duly qualified, so it should admonish us to set a guard over our thoughts, a watch at our lips, and post a sentinel over our actions; thereby preventing every unworthy thought, word, or deed, and preserving consciences void of offense toward God and toward man.

Your early and regular attendance upon the Communications of the Lodge, is necessary and expected, and I rely upon you to carefully meet this requirement.

(He is conducted to his place, and the Installing Officer addressing the Master, who rises, says:)

## CHARGE

Worshipful Master! (He rises.) The superintendence and government of the brethren who compose this Lodge having been committed to your care, you cannot be insensible of the obligations which devolve on you as their head; nor of your responsibility for the faithful discharge of the important duties of your position.

The honor, reputation and usefulness of your Lodge will materially depend on the skill and assiduity with which you manage its concerns, while the happiness of its members will be generally promoted, according to the zeal and ability with which you disseminate the genuine principles of our Institution.

For a pattern of imitation consider the great luminary of nature, which, rising in the east, regularly diffuses light and luster to all within its circle. In like manner it is your province to spread and communicate light and instruction to the brethren of your Lodge.



Forcibly impress upon them the dignity and high importance of Masonry; and seriously admonish them never to disgrace it. Charge them to practice out of the Lodge those duties which they have been taught in it; and, by amiable, discreet, and virtuous conduct, to convince mankind of the goodness of the Institution; so that when a man is said to be a member of it, the world may know that he is one to whom the burdened heart may pour out its sorrows; to whom distress may prefer its suit; whose hand is guided by justice, and whose heart is expanded by benevolence. In short, by a diligent observance of the By-Laws of your Lodge, the Constitutions of Masonry, and, above all, the Holy Scriptures, which are given as a rule and guide to your faith, you will be enabled to acquit yourself with honor and reputation, and lay up a crown of rejoicing, which shall continue when time shall be no more.

Brother Senior and Junior Wardens! (They rise.) You are too well acquainted with the principles of Masonry to warrant any distrust that you will be found wanting in the discharge of your respective duties. Suffice it to say that what you have seen praiseworthy in others, you should carefully imitate; and what in them may have appeared defective, you should in yourselves amend. You should be examples of good order and regularity; for it is only by a due regard to the laws, in your own conduct, that you can expect obedience to them from others. You are assiduously to assist the Master in the discharge of his trust, - diffusing light and imparting knowledge to all whom he shall place under your care. In the absence of the Master, you will succeed to higher duties. Your acquirements must, therefore, be such that the Craft may never suffer for want of proper instructions. From the spirit which you have hitherto evinced, I entertain no doubt that your future conduct will be such as to merit the applause of your brethren and the testimony of a good conscience.

Brethren of \_\_\_\_\_Lodge! (The Lodge is called up.) Such is the nature of our Constitution, that as some must of

necessity rule and teach, so others must learn to submit and obey. Humility in both is an essential duty. The officers who are appointed to govern your Lodge are sufficiently conversant with the rules of propriety and the laws of the Institution to avoid exceeding the powers with which they are entrusted; and you are of too generous dispositions to envy their preferment. I, therefore, trust that you will have but one aim, to please each other, and unite in the grand design of being happy and communicating happiness.

Finally, my brethren, as this Association has been formed and perfected in so much unanimity and concord, in which we may greatly rejoice, so may it long continue. May you long enjoy every satisfaction and delight which disinterested friendship can afford. May kindness and brotherly affection distinguish your conduct as men and as Masons. And may the tenets of our profession be transmitted through your Lodge, pure and unimpaired, from generation to generation.

Brother Marshal, make the proclamation.

Marshal: I am directed to proclaim, and I do hereby proclaim, that the Master, Wardens, and other officers, elected and appointed, of \_\_\_\_\_Lodge, No. \_\_\_\_\_, have been regularly installed into their respective stations and places for the ensuing year. All interested will take due notice, and govern themselves accordingly.

(The Installing Officer surrenders the East, and the Gavel, to the Master, who will seat the brethren, and assume full charge of any exercises or business that may follow; closing his Lodge in form if in private, if in public retiring to an adjoining room or waiting until those not Masons retire otherwise.)

## CHAPTER VI

### INSTALLATION OF GRAND LODGE OFFICERS

The Grand Master-elect is usually installed by the retiring Grand Master. The other officers may then be installed by the newly-installed Grand Master, or by the retiring Grand Master, or all of the Grand Officers-elect may be installed by some Past Grand Master whom the Grand Master-elect has selected for that purpose.

The Grand Marshal will see that the jewels of the officers to be installed, the Rods of the Grand Deacons and Grand Stewards, and two Swords, are placed near the East, arranged for convenient use

The INSTALLING OFFICER takes the East, and says:

Brethren of the Grand Lodge, we are about to install your Grand Officers for the ensuing year.

R.W. Grand Secretary, announce the names of the officers-elect. (The Grand Secretary does so.)

Brethren, you have heard the names of the Grand Officers-elect. If any of you know aught why any of them should not be installed, let him speak now, or forever after be silent. Hearing no objection, I will proceed.

Worshipful Grand Marshal, present the Grand Master-elect to the East.

**Grand Marshal:** Most Worshipful Grand Master, I have the honor to present to you our distinguished and worthy Brother , who, having been duly elected Grand Master of Masons for the ensuing year, now declares himself ready for installation.

**Installing Officer:** (Calls up Grand Lodge, and says:) Let us pray.

**Grand Chaplain:** Eternal source of life and light! We humbly implore Thy divine favor upon this occasion, and upon the Institution in whose service we are engaged. Bless the Grand Lodge and

its subordinates and all the Brotherhood, wherever dispersed. Make Freemasonry yet more helpful and beneficent to our race, and inspire all who are connected with it with an ardent love to Thee, to each other, and to every member of the human family. Bless now Thy servant who is about to assume a new and important relation to his brethren. Give him wisdom, give him strength, give him love. Enable him so to rule that he may keep in view the best interests of the Lodges and Brotherhood committed to his charge. As he is about to enter upon new and responsible duties, enable him so to discharge them as to win all hearts. Grant Thy blessing upon the officers who are to be associated with him. May they feel a just sense of their accountability, to Thee, and to the Fraternity; and may they ever be faithful and zealous, and assist in upholding the hands of their Chief in all good deeds. In Thee, o, God do we put our trust. Be Thou, our Friend, Conductor and Guide through all the vicissitudes of life, and at last receive us to Thyself, to dwell in Thy presence forevermore. Amen

**Response:** So mote it be.

**Installing Officer:** —Most Worshipful Brother, place your right hand over your heart and repeat after me your official obligation:

I solemnly promise, upon the honor of a Mason, that in the office of Grand Master of Masons, I will, to the best of my ability, strictly comply with the Constitution, Laws, Rules and Regulations of the Grand Lodge of Ancient Free and Accepted Masons of Minnesota, and all other ancient Masonic usages, so far as they shall come to my knowledge, and that I will enforce a strict obedience to the same, by all subject to my authority.

(The brethren are seated.)

Most Worshipful Brother, having thus solemnly pledged yourself to the faithful discharge of your duties, as the ruler of the Craft in Minnesota during the ensuing year, I now, with great pleasure, invest you with the insignia of your office. (He is invested by the Grand Marshal.)

Let me congratulate you, Most Worshipful Brother, on the honor of being raised from the level of equality, to the high station of Grand Master of Masons of Minnesota. We look up with confidence to a Brother whose person is endeared to us by that love of the Fraternity which is sanctified by the experience of many revolving years. May the Father of light, of life, and of love, invest you with His choicest gifts, and give you wisdom to perform acceptably the important duties which you are this day called upon to discharge. May His protecting care keep you from falling, and when you come to lay aside the emblem of your authority, may it be with the consciousness of having faithfully discharged your duty to Masonry, to the Lodges under your care and to your brethren; and late, very late, in life may you be transferred from the fading honors of an earthly Lodge to the mansions prepared for the faithful in another and better world. I now present you with this Gavel, the emblem of your authority, and welcome you (clasps his hand) to the East of the Grand Lodge of Minnesota, and ask the privilege of being the first to assure you of my fealty and obedience.

(The Grand Master is then covered, and the Installing Officer uncovers. The Grand Lodge is called up.)

Installing Officer: —I now hail, salute, and proclaim you Grand Master of Masons in Minnesota.

Most Worshipful Grand Master, behold your brethren.

Brethren, behold your Grand Master, and unite with me in giving him the Grand Honors. (Done.)

(If the Installation is private, the Grand Marshal then forms a procession of the brethren, who march in single file three times around the hall, signifying their respect and obedience by the usual distinctive signs in the several degrees. During or after the procession, the following Ode may be sung:)

## INSTALLATION ODE

### Air: America

Hail, Masonry divine, Glory of ages shine;  
    Long may'st thou reign  
Where'er thy Lodges stand,  
    May they have great command  
And always grace the land—  
    Thou art divine.  
Great fabrics still arise,  
    And grace the azure skies;  
Great are thy plans.  
    Thy noble orders are  
Matchless beyond compare;  
    No art with thee can share  
Thou art divine.  
    Hiram, the architect,  
Did all the craft direct  
    How they should build.  
Solomon, great Israel's King,  
    Did mighty blessings bring,  
Which still eternal spring,  
    Hail, Royal Art!

(If time is limited, the procession and Ode may be omitted. The Grand Master will seat the brethren, after which he may address the Grand Lodge. He will then announce his appointed officers and proceed with the installation, or cause it to proceed.)

**Installing Officer:** Brother Grand Marshal, present the other Grand Officers-elect and appointed for obligation.

(The Grand Marshal arranges the officers as their names are called by the Grand Secretary, in front of the Grand East, according to rank the Deputy Grand Master-elect, upon the right of the others.)

**Installing Officer:** You will each place your right hand over your heart and repeat after me your official obligation:

I solemnly promise, upon the honor of a Mason, that I will serve this Grand Lodge in the office to which I have been chosen, and will perform all the duties pertaining thereto, to the best of my ability.

(They will then be seated, and, with the appointed officers, will be severally presented by the GRAND MARSHAL, as follows:)

Most Worshipful Grand Master, I present to you our worthy Brother , to be installed as .

(As each officer is installed, he will be conducted to his station or place, during which there should be strains of instrumental music. The Installing Officer will deliver the several addresses as follows:)

### **TO DEPUTY GRAND MASTER**

Right Worshipful Brother, the office to which you have been elected is one of great dignity and much importance. In the absence of the Grand Master from the Communication of the Grand Lodge, or from the limits of its jurisdiction, you are invested with his powers and may exercise his prerogatives in presiding over the Craft: in his presence you are to assist him with your counsel and cooperation. Let our laws be your constant study, that you may be ever ready to exercise the functions of that more exalted office to which you are so liable to be called. I now, with much pleasure, invest you with your jewel, and congratulate you upon assuming a seat on the right of the Grand Master in the East.

### **TO SENIOR GRAND WARDEN**

Right Worshipful Brother, by the suffrages of your brethren, you have been elected their Senior Grand Warden, and I now invest you with the jewel of your office. Be assiduous in the performance of your duties, so that you may be a strength and support to the Grand Master. In the absence of your superior officers you will have

supreme command. While in your present position, look well to the West.

### **TO JUNIOR GRAND WARDEN**

Right Worshipful Brother, your brethren have shown their confidence in your fidelity by electing you their Junior Grand Warden, and I now invest you with the jewel of your office. Your previous devotion to the duties of Freemasonry is a sufficient guarantee that you will be a vigilant Warden. Look well to the South.

### **TO GRAND TREASURER**

Right Worshipful Brother, you have been elected to the responsible office of Grand Treasurer, and I now invest you with the jewel of your office. It is your duty to safely guard the funds of the Grand Lodge entrusted to your keeping, and pay them out only by order of the Grand Master, and with the consent of the Grand Lodge. This is an important trust, and your unimpeached integrity satisfies me that the trust is wisely reposed. Your regard for the Fraternity and for your good name will prompt you to the faithful discharge of the duties of your office.

### **TO GRAND SECRETARY**

Right Worshipful Brother, you have been elected to the important office of Grand Secretary, and I now invest you with the jewel of your office. It is your duty to receive all moneys due the Grand Lodge and promptly pay them to the Grand Treasurer; to observe all the proceedings of the Grand Lodge, and to make a fair record of what is proper to be written; to conduct the correspondence of the Grand Lodge and to act as the medium of intercourse between the Grand Master and the Craft. In the discharge of these extensive duties, let your carriage and behavior be marked by that promptitude



and discretion that will at once reflect credit on yourself, and honor on the Grand Lodge which you represent.

### **TO GRAND LODGE EDUCATION OFFICER**

Worshipful Brother, you have been appointed as the Grand Lodge Education Officer, and I now invest you with the jewel of your office. We are reminded that no Mason can possess the philosophy or inculcate the tenets of Masonry without sound education and life-long learning. By your assistance and encouragement, you will help the brethren of all degrees to study and enjoy ancient craft Masonry. Your place in Grand Lodge is in the East, on the immediate left of the Grand Master.

### **TO GRAND CHAPLAIN**

Worshipful Brother, you have been entrusted with the sacred position of Grand Chaplain and I now invest you with the jewel of your office. You will be required to lead the devotions at our communications and perform the functions of your holy calling at our public ceremonies. Though Masonry is not religion, it is emphatically religion's handmaid, and we are sure that in ministering at its altar, the services you perform will lose nothing of their vital influence, because they are practiced in that spirit of universal tolerance which distinguishes our Institution. Your place in Grand Lodge is in the East, on the left of the Grand Master.

### **TO GRAND ORATOR**

Worshipful Brother, you have been appointed to the office of Grand Orator, and I now invest you with the jewel of your office. Your reputation as a wise and accomplished Freemason has designated you for this mark of merit and distinction. Be it your constant care to maintain the confidence and respect of your brethren which

you now possess. Your place in the Grand Lodge is in the East, on the right of the Deputy Grand Master.

### **TO GRAND DEACONS**

Worshipful Brethren, you have been appointed Senior and Junior Grand Deacons, and I now invest you with the jewels of your office, and with these Rods as emblems of your authority. You will attend upon the Grand Master and Grand Wardens, and serve as their proxies in the active duties of the Grand Lodge. Let vigilance and discretion actuate you in the performance of your duties.

### **TO GRAND MARSHAL**

Worshipful Brother, you have been appointed Grand Marshal, and I now invest you with the jewel of your office, and present you with this Baton, as the emblem of your authority. You will present the Grand Officers for installation, make all proclamations directed by the Grand Master, arrange and conduct the processions of the Grand Lodge according to the prescribed forms, and preserve order therein. Skill and precision are essentially necessary to the faithful discharge of these duties. Your place is in front of and to the left of the East.

### **TO GRAND STANDARD BEARER**

Worshipful Brother, it is your duty to carry and uphold the Banner of the Grand Lodge on occasions of ceremony and public processions. Receive the jewel of your office, and let it remind you that you are never to part with the Standard when under your care, while you have life to defend it. Your place is in front of and to the right of the East.

## **TO GRAND SWORD BEARER**

Worshipful Brother, the Sword, which you will bear in all processions of the Grand Lodge, is the time-honored symbol of justice and authority. It is also the guardian and protector of the Standard of the Grand Lodge. Be faithful to your trust. You will be invested with the jewel of your office, which will remind you of your duty. Your place is at the left of the Grand Marshal.

## **TO GRAND STEWARDS**

Worshipful Brethren, you have been appointed Grand Stewards, and I now invest you with the jewels of your office, and with these White Rods as emblems of your position. It is your duty to provide for the comfort and convenience of the members of the Grand Lodge when in session, and to assist the Grand Deacons and other officers in the performance of their duties.

## **TO GRAND PURSUIVANT**

Worshipful Brother, you have been appointed Grand Pursuivant, and I now invest you with the jewel of your office. You are the messenger and herald of the Grand Lodge, and your place is near the inner door, where you will receive all reports from the Grand Tyler and announce the name and Masonic rank of all who desire admission, communicating the same to the Junior Grand Deacon. In Masonic processions you will precede the Grand Chaplain, carrying the three Great Lights.

## **TO GRAND TYLER**

Worshipful Brother, you have been appointed Grand Tyler, and I now invest you with the jewel of your office, and place in your hand this Sword, to enable you the more effectually to guard against the approach of cowans and eavesdroppers, and to suffer none to pass

or repass but such as are duly qualified. It is your duty to guard the doors of the Grand Lodge on the outside, to report to the Grand Pursivant those who desire to be admitted; to have the Grand Lodge rooms in order for business and properly heated and lighted; to take care of the Grand Lodge jewels, aprons, and other property during the sessions of the Grand Lodge, and to discharge such other duties as may be required of you by the Grand Lodge or Grand Master. Your punctual attendance is essentially necessary at every Communication.

You will now be conducted to your post of duty.

(The Grand Lodge is then called up.)

**Installing Officer:** Brother Grand Marshal, make the proclamation.

**Grand Marshal:** I am directed to proclaim, and I do hereby proclaim, that the Most Worshipful Grand Master and other officers, elected and appointed, of this Grand Lodge, have been regularly installed into their respective stations and places, in Ample Form. All interested will take due notice, and govern themselves accordingly.

Installing Officer: Brethren of the Grand Lodge, unite with me in giving the Grand Honors. (Done.)

(The Installing Officer surrenders the East, and the Gavel, to the Grand Master, who will seat the brethren.)

(If time allows, the ceremonies should be interspersed with appropriate music.)

## CHAPTER VIII

### BREAKING GROUND FOR MASONIC TEMPLE

Prepared by William P. Roberts, Past Grand Master

Having regularly applied for and received a dispensation from the Grand Master of Masons, for the purpose, there may be held a formal ceremony of “breaking ground” for the erection of a Masonic Temple, by a Masonic Lodge or Lodges interested.

Any such ceremony should in no respect follow the lines of the ceremonies prescribed for the laying of the corner stone of such building, for that would tend to detract from the latter ceremony, which has ever been regarded as the real commencement of the building to be erected.

For this and all other ceremonial occasions—Laying Corner Stones, Funerals, etc., the Lodge is formally opened before and closed following the ceremony. After it is opened, and is ready to proceed to the place of service, the Marshal is ordered to form and conduct the procession to the place of the service. The Lodge remains open until it is formally closed. “The Great Lights” are carried in the procession, open, and upon the return are placed upon the altar, still open, for the closing. The Lodge Room must be closed and locked in the meantime.

There may properly be a short procession, direct from the present meeting place of the Lodge, to the site of the new building—the procession forming in the usual order for public occasions. When the site is reached, the following program may be followed:—

1. Music.
2. **Master:** —Brother Marshal, you will proclaim quiet and order.
3. **Marshal:** —In obedience to the order of the Worshipful Master, I do now require all persons here assembled, to be silent, preserve order and give attention to the ceremonies about to occur.

4. **Master:** —We are assembled here to start, in a formal manner, a great enterprise for our beloved Fraternity, and for this community. Let us, then, as we are taught, bow heads reverently while we are led in prayer by our Chaplain.

5. **Chaplain:** —Our Heavenly Father! We lift our hearts in praise and thanksgiving to Thee, for having brought us to this hour, and to this occasion; for having permitted us to see the beginnings of this work,—very near and dear to all our hearts,—the building of a Masonic Temple in our city. We reverently pray that Thou wilt abundantly bless and prosper this enterprise, and wilt grant to all the brethren here, and elsewhere, in our city, fresh courage and inspiration for united effort for the successful carrying on and completion of this great undertaking. Bless us richly with Thy constant oversight and care, during all the progress of the work, which we this day here begin. Amen!

6. **All Brethren:** —So mote it be.

7. Chant. (“Hear us, Heavenly Father,” or some other appropriate response.)

8. **Master:** —Brethren! We are to start this morning, a long hoped for and long deferred enterprise,— the erection of a Masonic Temple, of our own, in .

Our hearts are all naturally very full of gladness, as we realize as never before, that this day brings us face to face with the actual commencement of our new building, and that from this moment forward we may assuredly and confidently feel that the fruition of our hopes and longings, as Masons, is near and we will soon be in a home of our own.

I now, as Worshipful Master of \_\_\_\_\_ Lodge No. \_\_\_\_\_ A. F. & A. M., formally start this memorable and auspicious undertaking, by turning the first spade of earth upon the site secured for our new Temple. (Does so.) And I do now declare this

great work begun. I direct the contractor to assume charge and to proceed with all expedition to prepare the excavation, in which is to be laid the solid foundations of the Masonic Temple of . to the end that the erection thereof, shall not be long delayed.

9. Music.

10. **Master:** —The Marshal will make the proclamation.

11. **Marshal:** —I now proclaim, that the ground has been formally broken, for the Masonic Temple of , Minnesota, by the solemn ceremonies of our Fraternity, and that the work of carrying out the contract for its erection, may now proceed.

12. **Master:** —The Chaplain will pronounce the benediction.

13. **Chaplain:** —(Pronounces a benediction.)

14. (An appropriate address may precede the benediction if desired, but should be short and not trench upon the matter which will likely be covered by the oration, at the laying of the Corner Stone, later.)

15. Music

(The procession will again form, and proceed in orderly manner, to the hall, where the Lodge will be closed, as it must have been opened before starting to the site.)

## CHAPTER IX

### LAYING CORNER STONES

Prepared by Thomas Montgomery, Past Grand Secretary

No corner stone should be laid with Masonic ceremonies, except those of important public structures including churches, or buildings to be used for Masonic purposes; and then only by special request made to the Grand Master by the proper authorities. The ceremonies can be conducted only by the Grand Master or his duly appointed proxy. The Lodge in the place where the building is to be erected, or the one most directly interested, with permission from the Grand Master, may invite such neighboring Lodges and other Masonic bodies as is deemed proper. The chief magistrate and other officers of the place should also be invited to attend on the occasion.

All Lodges participating must also be formally opened before and closed after the ceremony, - observing the rule therefore stated in the "Ceremony for Breaking Ground."

At the appointed time, the Grand Master, or his proxy, assisted by other Grand Officers present, and by enough Past Masters, or other brethren to act as Grand Officers, will open an Occasional Grand Lodge in the Lodge room or some other convenient place, and after being properly instructed and everything in readiness, a procession will be formed under the direction of the Grand Marshal in the following order:



Grand Tyler  
(with drawn Sword)

Grand Steward (carrying rod)	Grand Pursuivant (carrying Bible, Square and Compass)	Grand Steward (carrying rod)
Grand Marshal		
Grand Chaplain		Grand Orator
Grand Secretary		Grand Treasurer

Past Grand Officers  
(in inverse order of rank, two abreast, juniors in front)

Architect  
(if a Mason, otherwise a Past Master,  
carrying Square, Level and Plumb.)

Junior Grand Warden (carrying vessel of oil)	Senior Grand Warden (carrying vessel of wine)
---	--

Deputy Grand Master  
(carrying vessel of corn—[wheat])

Master of Oldest Lodge  
(carrying Book of Constitutions)

**GRAND MASTER**

Junior Grand Deacon (carrying rod)	Senior Grand Deacon (carrying rod)
---------------------------------------	---------------------------------------

Grand Standard Bearer  
(with American Flag)

Grand Sword Bearer  
(with drawn sword)

The procession thus formed will proceed to join the general procession, if any, which, if composed of the bodies named below, should be formed in the following order, leading the Grand Lodge, viz.:

Music, Military, Citizens, Societies and Organizations, Music, Grand Marshal, Knights Templar as escort, (If more than one Commandery, the senior leading) Royal Arch Masons, Master Masons-by Lodges, (If more than one Chapter or Lodge, the junior leads in each case) Music, Knights Templar as escort to Grand Lodge, Chief Magistrate and Civil Officers of the place, Grand Lodge, in the order before above.

When the head of the procession reaches the site of the new building it opens to the right and left, faces inward, and uncovers. The Grand Master, preceded by the Grand Marshal and Grand Tyler, and followed by the other Grand Officers and the chief magistrate and civil officers of the place will pass through the lines, ascend to the platform and be seated. As the Grand Master and others advance, the remainder of the procession will counter-march and surround the platform. The corner stone should have engraved on its face the words, "Laid by the Masonic Fraternity," with the date, the year of Masonry, the name of the Grand Master, and such other particulars as may be deemed proper. The stone should be suspended about six feet from its bed by a machine having suitable arrangements for slowly lowering it to its place.

## **ORDER OF PROCEEDINGS**

### **Band Music—America**

**Grand Master:** —Brother Grand Marshal, you will command silence.

**Grand Marshal:** —In obedience to the order of the Most Worshipful Grand Master of Masons of Minnesota, I do now require all persons who are here assembled to preserve silence and to observe due order and decorum during the ceremonies of this occasion.

**Grand Master:** —RW Grand Secretary, you will read the invitation.

(The Grand Secretary reads the letter.)

**Grand Master:** —Brethren, we are about to commence a great work, and Masonry teaches us that before entering upon any important undertaking we should first invoke the blessing of Deity. Let us unite with our Grand Chaplain in the performance of that duty. Uncover!

## **PRAYER**

Almighty God! Who hath given us grace at this time, with one accord, to make our common supplication unto Thee, and hast

promised that where two or three are gathered together in Thy name Thou wilt grant their requests; fulfill now, O Lord! the desires and petitions of Thy servants as may be most expedient for them; granting us in this world knowledge of Thy truth, and in the world to come, life everlasting. Amen.

**Response:** So mote it be.

(Music or ode by quartet)

**Grand Master:** —RW Grand Treasurer, it has ever been the custom, on occasions like the present, to deposit within a cavity in the corner stone, to be laid, certain memorials of the period at which the edifice was erected, so that in the lapse of ages, if the fury of the elements, or the slow but certain ravages of time, should lay bare its foundation, an enduring record may be found to bear testimony to the energy, industry and culture of the people of that period. Has such a deposit been prepared for this occasion?

**Grand Treasurer:** —It has, MW Grand Master, and the various articles of which it is composed are safely enclosed within the casket now before you.

**Grand Master:** —RW Grand Secretary, you will read, for the information of the people here assembled, a record of the contents of the casket.

**Grand Secretary:** —The casket contains the following:  
(Reads a list of the articles contained in casket.)

**Grand Master:** —Brothers Grand Treasurer and Grand Secretary, deposit the casket in the cavity prepared for it, and may the Supreme Architect of the Universe grant that ages shall pass away ere it again be seen of men.

(They place the box in the cavity while a band plays soft music.)

**Grand Secretary:** —MW Grand Master, your order has been obeyed.

(The **Grand Marshal**, receiving the trowel from Architect, presents it to the Grand Master.)

**Grand Master:** —The Trowel in operative Masonry is used to spread the cement which unites the building into one common mass. Its symbolic use is to spread the cement of brotherly love and affection which unites into one great Fraternity all members of the Masonic family, wheresoever dispersed around the globe.

(The Grand Marshal collects the square, level and plumb from the Architect, and presents them to the Grand Master, saying:)

**Grand Marshal:** —MW Grand Master, I present you with these working tools of operative Masonry, which were considered by our ancient brethren as the most valuable jewels of the Lodge symbols of important truths, and teaching lessons of wisdom and morality.

(**Grand Master**, addressing Deputy Grand Master Senior and Junior Grand Wardens, says:)

Right Worshipful Brethren, you will receive the implements of your office. With your assistance and that of the Craft, I will now proceed to lay the corner stone of this edifice, according to the custom of our Fraternity. Brother Grand Marshal, you will direct the craftsmen to furnish the cement, and prepare to lower the stone.

(A band plays soft music until the stone is laid. The Grand Master spreads a portion of the cement. The stone is then lowered slowly one-third the distance, when it is stopped. It is again lowered and stopped. It is again lowered to its proper place.)

**Grand Master:** —RW Deputy Grand Master what is the proper implement of your office?

**Deputy Grand Master:** —The SQUARE.

**Grand Master:** —What are its moral and Masonic uses?

**Deputy Grand Master:** —To square our actions by the square of virtue, and to prove our work.

**Grand Master:** —Apply the square to those portions of the corner stone which should be square and make report.

(Square is applied to the four upper corners.)

**Deputy Grand Master:** —M W Grand Master, I find the stone to be square. The craftsmen have done their duty.

(Music, one verse)

**Grand Master:** —RW Senior Grand Warden, what is the proper implement of your office?

**Senior Grand Warden:** —The LEVEL.

**Grand Master:** —What are its moral and Masonic uses?

**Senior Grand Warden:** —Morally, it teaches equality, and we use it to lay horizontals.

**Grand Master:** —Apply the level to that portion of the stone which needs to be proved and make report.

(Level is applied to the top surface.)

**Senior Grand Warden:** —M W Grand Master, I find the stone to be level. The craftsmen have done their duty.

(Music, one verse)

**Grand Master:** —RW Junior Grand Warden, what is the proper implement of your office?

**Junior Grand Warden:** —The PLUMB.

**Grand Master:** —What are its moral and Masonic uses?

**Junior Grand Warden:** —Morally, it teaches rectitude of conduct, and we use it to try perpendiculars

**Grand Master:** —Apply the plumb to the stone and make report.

(Plumb is applied to the side of stone.)

**Junior Grand Warden:** —MW Grand Master, I find the stone to be plumb. The craftsmen have done their duty.

(Music, one verse)

**Grand Master:** —(Striking the stone three times with his gavel) This corner stone has been tested by the proper implements of Masonry. I find that the craftsmen have skillfully and faithfully performed their duty, and I do declare the stone to be plumb, level and square, well formed, true and trusty, and correctly laid according to the rules of our Ancient Craft. May the building be conducted and completed amid the blessings of Plenty, Health and Peace. Amen.

**Response:** So mote it be.

(Music)

**Grand Master:** —Brother Grand Marshal, you will present the elements of consecration to the proper officers.

(Grand Marshal presents Vessel of Corn to the Deputy Grand Master, the Wine to the Senior Grand Warden and the Oil to the Junior Grand Warden.)

**Deputy Grand Master:** —(Scattering corn on stone) I scatter this Corn as an emblem of Plenty. May the blessings of bounteous Heaven be showered upon us, and upon all patriotic and benevolent undertakings, and inspire the hearts of the people with Virtue, Wisdom and Gratitude. Amen

**Response:** So mote it be.

**Senior Grand Warden:** —(Pouring wine on stone) I pour this Wine as an emblem of Joy and Gladness. May the Great Ruler of the Universe bless and prosper our National, State and City Governments and may the Union of the States in harmony and brotherly love, endure through all time. Amen.

**Response:** So mote it be.

**Junior Grand Warden:** —(Pouring oil on stone) I pour this Oil as an emblem of Peace. May its blessings abide with us continually. May the Grand Master of Heaven and Earth shelter and protect the widow and orphan, the afflicted and the sorrowing everywhere, and may our loved Fraternity long exist to pour the Oil of joy upon the hearts of all who are in distress. Amen.

**Response:** So mote it be.

**Grand Master:** —(Extending his hands) May the blessing of Almighty God be upon this undertaking. May He protect the workmen from every accident, long preserve the structure from decay, and grant to us all a needful supply of the Corn of Nourishment, the Wine of Refreshment and the Oil of Joy. Amen.

**Response:** So mote it be.

**Grand Marshal:** —MW Grand Master, I present to you the Architect of this building. He is ready, with craftsmen, for the work, and asks the tools for his task.

**Grand Master:** —Worthy sir (or brother), having thus, as Grand Master of Masons, laid the cornerstone of this new building, I now return to you these implements of operative Masonry (presents square, level and plumb) entrusting you with the superintendence and direction of the work, having full confidence that by your skill and tact, aided by faithful craftsmen, a structure will arise which will add new luster to this city and state.

**Grand Master:** —Brother Grand Marshal, you will make the proclamation.

**Grand Marshal:** —In the name of the Most Worshipful Grand Lodge of Ancient Free and Accepted Masons of Minnesota, I now proclaim, that the corner stone of the structure here to be erected, has this day been proven square, level and plumb, true and trusty, and laid according to the ancient custom of the Craft, by the Grand Master of Masons.

(An ode may be sung, after which the Grand Master introduces the Grand Orator.)

At the close of the oration, the Grand Chaplain will pronounce the following or some other suitable benediction:

### **BENEDICTION**

Glory be to God on High, and on earth peace, good will toward men! O Lord, we most heartily beseech Thee with Thy favor to behold and bless this assemblage. Pour down Thy mercies, like the dew that falls upon the mountains, upon Thy servants engaged in the solemn ceremonies of this day. Bless, we pray Thee, all the workmen who shall be engaged in the erection of this edifice; keep them from all forms of accident and harm, and grant them health and prosperity while they live. And finally, we pray that when our earthly toils and labors are ended we may all, through Thy mercy, wisdom and forgiveness, attain everlasting joy and felicity in the mansions prepared for us in that temple not made with hands, eternal in the heavens. Amen.

**Response:** So mote it be.

(After which, the Grand Lodge, with escort, returns to the place from whence it started, and is closed. The Lodges and other Masonic bodies return to their respective halls.)



## CHAPTER X

### DEDICATION OF MASONIC HALLS

Every Hall used exclusively for Masonic purposes should be dedicated.

The ceremonies must be conducted by the Grand Master or his duly appointed proxy, and may be private or public.

At the appointed time the Grand Master, or his proxy assisted by other Grand Officers present, and by enough Past Masters or other brethren to act as Grand Officers, will open an Occasional Grand Lodge, in a room near the Hall to be dedicated.

The officers and members of the Lodge, and visiting brethren, properly clothed, will occupy the Hall, the Master only being at his station, in the East

A small table should be placed between the altar and the East, on which to put the “Lodge,” (a small oblong box covered with white cloth) and three tapers should be placed on or near the table, at the east, west and south, respectively.

When all is in readiness, the Grand Marshal will form the Grand Lodge in procession in the following order, and move to the Hall to be dedicated:

Grand Tyler (with drawn sword)	
Junior Grand Steward (carrying rod)	Senior Grand Steward (carrying rod)
The “Lodge” (carried by four brethren)	
Grand Marshal	
Grand Pursuivant (carrying Bible, Square and Compass)	
Grand Chaplain	Grand Orator
Grand Secretary	Grand Treasurer
Junior Grand Warden (carrying vessel of corn)	Senior Grand Warden (carrying vessel of wine)

Deputy Grand Master  
(carrying vessel of oil)  
Master of Oldest Lodge  
(carrying Book of Constitutions)

Junior Grand Deacon (carrying rod)	Senior Grand Deacon (carrying rod)
---------------------------------------	---------------------------------------

Grand Master  
Grand Standard Bearer  
Grand Sword Bearer  
(with drawn sword)

As the procession enters the Hall, the **GRAND MARSHAL** will announce, “**THE MOST WORSHIPFUL GRAND LODGE OF MINNESOTA,**” when the brethren inside will all rise. The procession will pass directly to the East, one line on each side of the altar, halt and face inward. The “Lodge” will be placed on the table, the vessels of corn, wine and oil set thereon and covered with a linen spread, the tapers lighted, the three Great Lights laid Upon the Altar, and the Book of Constitutions placed upon the pedestal in the East.

The Master leading the brethren will then give the Grand Honors, after which the Grand Marshal will escort the Grand Master to the East; the other Grand Officers following, will take their respective stations and places, and the brethren will be seated. If the ceremonies are private, the Grand Master or his proxy may open the Occasional Grand Lodge in the Hall. The following ode may now be sung and a suitable prayer offered:

**Air: Old Hundred**

Master Supreme! accept our praise;  
Still bless this consecrated band;  
Parent of light! illumine our ways,  
And guide us by Thy sovereign hand.  
May Faith, Hope, Charity, divine,  
Here hold their undivided reign  
Friendship and Harmony combine  
To soothe our cares—to banish pain.

May pity dwell within each breast,  
Relief attend the suffering poor;  
Thousands by this, our Lodge, be blest,  
Till worth, distresse'd, shall want no more.

(The **MASTER** of the Lodge whose Hall is to be dedicated then rises, and addresses the Grand Master as follows:)

Most Worshipful Grand Master, the brethren of Lodge, No being animated with a desire to promote the honor and interest of the Craft, have erected and furnished this Masonic Hall, for their convenience and accommodation. They are desirous that the same should be examined by the Most Worshipful Grand Lodge; and if it should meet their approbation, that it be solemnly dedicated to Masonic purposes, agreeably to ancient form and usage.

(The **ARCHITECT** or brother who has had the management of the structure then addresses the Grand Master as follows:)

Most Worshipful Grand Master, having been intrusted with the superintendence and management of the workmen employed in the construction of this edifice, and having according to the best of my ability, accomplished the task assigned me, I now return my thanks for the honor of this appointment, and beg leave to surrender up the implements which were committed to my care, when the foundation of this building was laid (presenting to the Grand Master the Square, Level, and Plumb), humbly hoping that the exertions which have been made on this occasion will be crowned with your approbation, and that of the Most Worshipful Grand Lodge.

(To which the **GRAND MASTER** replies:)

Brother Architect, the skill and fidelity displayed in the execution of the trust reposed in you at the commencement of this undertaking, have secured the entire approbation of the Grand Lodge, and they sincerely pray that this edifice may continue a lasting monument of the taste, spirit and liberality of its founders.

(The **DEPUTY GRAND MASTER** then rises and says:)

Most Worshipful Grand Master, the Hall in which we are now assembled, and the place upon which it has been constructed, having met with your approbation, it is the desire of the officers and brethren of this Lodge that it should be now dedicated, according to ancient form and usage.

(The **GRAND MASTER** replies)

Right Worshipful Deputy Grand Master, agreeably to the request of the brethren, we will now proceed with the ceremonies.

Brother Grand Marshal, form the Grand Officers in procession.

(The “Lodge” is slowly uncovered by the Grand Marshal, who will then form the Grand Officers, in reversed order of rank in single file on the north side of the Hall facing east, the Grand Tyler leading, and the following officers in rear:)

Junior Grand Warden  
(carrying vessel of corn)

Senior Grand Warden  
(carrying vessel of wine)

Deputy Grand Master  
(carrying vessel of oil)

Junior Gr. Deacon  
(carrying rod)

Grand Master

Senior Gr. Deacon  
(carrying rod)

The **GRAND MASTER** will take his position as the rear of the procession passes the East. The procession will move once around the “Lodge,” passing east of the altar, while the first stanza of the ode will be sung by the choir, as follows:

**Air: Old Hundred**

Genius of Masonry, descend,  
And with thee bring thy spotless train;  
Constant our sacred rites attend,  
While we adore thy peaceful reign.

(When the Grand Master arrives at the East, the procession halts, and faces inward; the Master calls up the brethren; the Grand Officers kneel, and the GRAND CHAPLAIN offers the consecration prayer.)

## **CONSECRATION PRAYER**

Almighty and ever glorious and gracious Lord God, Creator of all things, and Governor of everything Thou hast made, mercifully look upon Thy servants now assembled in Thy name, and in Thy presence, and bless and prosper all our works begun, continued, and ended in Thee. Graciously bestow upon us wisdom in all our doings; strength of mind in all our difficulties, and the beauty of harmony and holiness in all our communications and word. Let Faith be the foundation of our Hope, and Charity the fruit of our obedience to Thy revealed will.

May all who shall be lawfully appointed to rule herein according to our constitutions, be under Thy special guidance and protection, and faithfully observe and fulfill all their obligations to Thee and to the Lodge.

May all who come within these consecrated walls have but one heart and one mind, to love, to honor, to fear, and to obey Thee, as Thy majesty and unbounded goodness claim; and to love one another, as Thou hast loved us. May every discordant passion be here banished from our bosoms. May we here meet in Thy presence as a band of brethren, who were created by the same Almighty Parent, are daily sustained by the same beneficent hand, and are traveling the same road to the gates of death. May we here have Thy Holy Word always present to our mind, and religion, and virtue, love, harmony, and peaceful joy reigning triumphant in our hearts.

May all the proper work of our Institution that may be done in this house be such as Thy wisdom may approve and Thy goodness prosper. And, finally, graciously be pleased, O Thou Sovereign Architect of the Universe, to bless the Craft, wheresoever dispersed, and make them true and faithful to Thee, to their neighbors, and to themselves. And when the time of our labor is drawing near to an

end, and the pillar of our strength is declining to the ground, graciously enable us to pass through the “valley of the shadow of death” supported by Thy rod and Thy staff, to those mansions beyond the skies, where love, and peace, and joy forever reign before Thy throne. Amen.

**Response:** So mote it be.

(The brethren are seated.)

[The **GRAND OFFICERS** will rise and march around the “Lodge” as before, during which the second stanza of the ode will be sung:]

Bring with thee virtue, brightest maid;  
Bring Love, bring Truth, bring Friendship here,  
While Social Mirth shall lend her aid  
To soothe the wrinkled brow of Care.

(After halting and facing inward the **JUNIOR GRAND WARDEN** advances and presents the vessel of Corn [wheat] saying:)

Most Worshipful Grand Master! In the dedication of Masonic Halls it has been of immemorial custom to pour Corn upon the Lodge, as an emblem of nourishment. I, therefore, present to you this vessel of Corn, to be employed by you according to ancient Masonic form and usage.

(The **GRAND MASTER** calls up the brethren by striking the “Lodge” thrice with his gavel, uncovers, and pours the Corn upon the “Lodge,” saying:)

In the name of the Great Jehovah, to whom be all honor and glory, I do solemnly dedicate this Hall to Freemasonry.

(The Grand Honors are then given once, the brethren are seated. The third procession is made as before. The third stanza is sung:)

Bring Charity, with goodness crowned,  
Encircled in thy heavenly robe;  
Diffuse thy blessings all around,  
To every corner of the globe.

(After halting and facing inward, the **SENIOR GRAND WARDEN** advances and presents the vessel of Wine, saying:)

Most Worshipful Grand Master! Wine, the emblem of refreshment, having been used by our ancient brethren in the dedication and consecration of their Lodges; I present to you this vessel of Wine, to be used on the present occasion according to ancient Masonic form and usage.

(The **GRAND MASTER** gives three knocks with his gavel as before, at which the brethren arise, and he sprinkles the Wine upon the “Lodge,” saying:)

In the name of the Holy Saint John, I do solemnly dedicate this Hall to Virtue.

(The Grand Honors are given twice. The brethren are seated. The fourth procession is made as before. The fourth stanza is sung:)

To Heaven’s high Architect all praise,  
All praise, all gratitude be given  
Who deigned the human soul to raise  
By mystic secrets, sprung from heaven.

(After halting and facing inward, the **DEPUTY GRAND MASTER** advances and presents the vessel of Oil, saying:)

Most Worshipful Grand Master! I present to you, to be used according to ancient custom, this vessel of Oil, an emblem of that joy which should animate every bosom on the completion of any important undertaking.

(The **GRAND MASTER** calls up the brethren by three knocks as before, and pours the oil upon the “Lodge,” saying:)

In the name of the whole Fraternity, I do solemnly dedicate this Hall to Universal Benevolence.

(The Grand Honors are given thrice, when the **GRAND CHAPLAIN** advances and makes the following:)

## INVOCATION

And may the Lord, the giver of every good and perfect gift, bless the brethren here assembled, in all their lawful undertakings, and grant to each one of them in needful supply, the Corn of nourishment, the Wine of refreshment, and the Oil of joy. Amen.

**Response:** So mote it be.

(The **GRAND MARSHAL** then covers the “Lodge,” after which the **GRAND MASTER** will resume his chair, and the other Grand Officers will take their respective stations and places.)

**Grand Master:** —Brother Grand Marshal, make proclamation that the Hall in which we are now assembled, has been solemnly dedicated to the purposes of Freemasonry in Ample Form.

**Grand Marshal:** —I am directed by the Most Worshipful Grand Master to proclaim, and I do proclaim, that this Hall has been solemnly dedicated to the purposes of Freemasonry in Ample Form. All interested will take due notice thereof, and govern themselves accordingly.

(The following ode may then be sung:)

### Air: Portuguese Hymn

O, God! Thou has reared, in Thy glorious might,  
The temple of nature whose arch is the sky;  
Exalted its pillars, and covered it o'er  
With starry decked heavens in beauty on high.  
With faith like the Fathers, we humbly uprear  
This lowlier temple of Brotherly Love;  
Thy book on its altar, Thy trust in our hearts,  
We consecrate all to the Master above.  
O! ever may Wisdom be found in its East,  
Contriving for all in true Friendship and Love;  
The strength of King Hiram abound in the West,  
Supporting the fabric with faith from above.  
May the South glow with Beauty, the whole to adorn,  
And ever remind us of Him who was slain;



Like Him may we suffer; like Him, when we die,  
Be raised from the grave unto glory again.

(The following, or an appropriate original oration, may then be delivered, and the ceremonies concluded with music:)

### **Oration**

Brethren, the ceremonies we have performed are not unmeaning rites, nor the amusing pageants of an idle hour, but have a solemn and instructive import. Suffer me to point out to you, and to impress upon your minds, the ennobling sentiments they are so well adapted to convey.

This Hall, designed and built by Wisdom, supported by Strength and adorned in Beauty, we first consecrated in the name of the Great Jehovah; which teaches us, in all our works, begun and finished, to acknowledge, adore, and magnify Him. It reminds us, also, in His fear to enter the door of the Lodge, to put our trust in Him while passing its trials, and to hope in Him for the reward of its labors.

Let its altar, then, be devoted to His service, and its lofty arch resound with His praise! May the eye which seeth in secret witness here the sincere and unaffected piety which withdraws from the engagements of the world to silence and privacy, that it may be exercised with less interruption and less ostentation.

Our march around the “Lodge” reminds us of the travels of human life, in which Masonry is an enlightened, a safe, and a pleasant path. Its tessellated pavement in mosaic-work, intimates to us the checkered diversity and uncertainty of human affairs. Our step is time; our progression, eternity.

Following our Ancient Constitutions, with mystic rites, we dedicated this Hall to the honor of Freemasonry.

Our best attachments are due to the Craft. We find our joy in its prosperity, and we honor ourselves in paying it honor. But its worth transcends our encomiums, and its glory will out sound our praise.

Brethren: It is our pride that we have our names on the records of Freemasonry. May it be our high ambition that they should shed a luster on the immortal page!

The Hall is also dedicated to Virtue.

This worthy appropriation will always be duly regarded while the moral duties which our sublime lectures inculcate, with affecting and impressive pertinency, are cherished in our hearts and illustrated in our lives.

As Freemasonry aims to enliven the spirit of philanthropy, and promote the cause of charity, so we dedicate this Hall to Universal Benevolence, in the assurance that every brother will dedicate his affections and his abilities to the same generous purpose; that while he displays a warm and cordial affection to those who are of the Fraternity, he will extend his benevolent regards and good wishes to the whole family of mankind.

Such, my brethren, is the significant meaning of the solemn rites we have just performed, because such are the peculiar duties of every Lodge. I need not enlarge upon them now, nor show how they diverge, as rays from a center, to enlighten, to improve, and to cheer the whole circle of life. Their import and their application are familiar to you all. In their knowledge and their exercise may you fulfill the high purposes of the Masonic Institution!

How many pleasing considerations, my brethren, attend the present interview! While in almost every other association of men, political animosities, contentions, and wars, interrupt the progress of humanity and the cause of benevolence, it is our distinguished privilege to dwell together in peace, and engage in plans to perfect individual and social happiness. While in many other nations our Institution is viewed by politicians with suspicion, and by the ignorant with apprehension, in this country its members are too much respected and its principles too well known to make it the object of

jealousy or mistrust. Our private assemblies are unmolested, and our public celebrations attract a more general approbation of the Fraternity. Indeed, its importance, its credit, and, we trust, its usefulness, are advancing to a height unknown in any former age. The present occasion gives fresh evidence of the increasing affection of its friends, and this noble apartment, fitted up in a style of such elegance and convenience, does honor to Freemasonry, as well as reflects the highest credit on the respectable Lodge, for whose accommodation and at whose expense it is erected.

We offer our best congratulations to the Worshipful Master, Wardens, officers and members of Lodge. We commend your zeal, and hope it will meet with the most ample recompense. May this Hall be the happy resort of piety, virtue and benevolence! May it be protected from accident, and long remain a monument of your attachment to Freemasonry! May your Lodge continue to flourish; your union to strengthen; and your happiness to abound! And when you, and we all, shall be removed from the labors of the earthly Lodge, may we be admitted to the brotherhood of the perfect in the building of God, the Hall not made with hand, eternal in the heavens!

(The Grand Master calls up the brethren and requests the Grand Chaplain to pronounce a suitable benediction, after which the Grand Officers return to their apartment in the same order as at entering and the Occasional Grand Lodge is closed; or if the ceremonies are private it may be closed without retiring.)

(The Master may seat the brethren after the Grand Officers have retired, or dismiss the assembled at his pleasure.)

## CHAPTER XI

### FINAL MASONIC RITES

Should a Mason or his nearest of kin request final Masonic Rites the request shall be honored by the Lodge of which he was a member. When a Lodge is to conduct or share in the final Rites its members shall be immediately notified to assemble at the Lodge Hall at the designated time. (In case of an emergency they shall assemble at such place as may be designated by the Master of the Lodge, a Lodge of Sorrow having already been opened in accordance with the General Regulations.)

On receiving word of a Brother's death in some distant place and his body is not being returned for burial, the nearest Lodge to the deceased shall be notified of his death and requested to give him Masonic burial, if the family so desires. Furthermore, a Memorial Service may be held for him by the Lodge of which he was a member, at a time convenient to its members and to which his relatives and friends may be invited.

When a Lodge officiates at the final rites for a Brother, it should be understood that it is under no obligation to share any part of the expense incident thereto, it being left to the Lodge what relief it gives, if any.

When Masons attend in a body the final Rites for a Brother they shall be required to wear their aprons only at such place or places where they are in charge of the Services. When formed in procession they shall immediately precede the deceased.

If the deceased was a Grand Lodge Officer or a permanent member of the Grand Lodge the Grand Master shall be notified and the local Lodge shall await his instructions. When a Lodge shares in the final Rites with a Clergyman, the Master of the Lodge or the

Brother appointed by the Master to conduct the Masonic service, shall confer with the Clergyman and coordinate the services.

It is the obligation of the Master of each Lodge to see that at least two members of his Lodge are sufficiently familiar with the final Rites Ritual to be able to conduct the Services proficiently in keeping with Masonic Traditions.

No funeral service can be laid down to fit every occasion. It is permissible, therefore, to transfer or omit paragraphs as circumstances require. The service presented here is effective if properly presented. It is necessary that the officers who deliver it should study it carefully. It should be followed as closely as seems warranted under the circumstances of the occasion. In case of need almost any part may be omitted, but to constitute Burial with Masonic Honors, two elements are essential and these may not be omitted:

1. The Presentation of the Apron and
2. The Tribute of Acacia.

Final Masonic Rites should in no way reproduce or copy the ritual services of the church, synagogue or mosque. Our Rites are a Masonic tribute to the deceased Brother and they must and should affirm in our own language and symbolism the teachings of our Ancient Craft, not only about virtue and morality, but also our belief in the immortality of the soul. They are also our means of extending our sympathy and sorrow to the family and friends who remain. The language, prayers, and scriptural texts used should reflect the best Masonic traditions. When addressing the Deity in prayer it should never be done in a way that excludes Brothers of other faiths and of necessity should be inclusive and universal, not sectarian or denominational.

## PART I

To be used at Mortuary, Chapel, Hall or Church

A Brother has been called from his earthly labor to his Eternal reward and we are here to honor his memory and to offer our heartfelt sympathy to his loved ones.

In our sorrow we turn to The Great Light of Masonry, God's Word, for guidance, strength and comfort. (One of the following passages of Scripture may be used and given by the Brother in charge, the Chaplain or other designated person:) 1 Cor. 13:12; II Cor. 5:1; Ecclesiastes 12:1-7; Psalm 23; Psalm 90:1, 2, 4-6, 12, 14, 17; Psalm 91: 1-6, 9-16; Psalm 121, or other suitable passages from The Scriptures.

Let us pray: (Prayer may be given by the Brother in Charge, The Chaplain or other designated Brother) Almighty and Everlasting God, we desire to acknowledge Thee in all our ways and in all the events which befall us. In sorrow of heart, yet in quietness and confidence, we have gathered for these last solemn and tender offices of faith and love. Lift us above the shadow and sadness of mortality into the light of Thy Countenance and the comfort of Thy presence. Inspire our hearts with wisdom that we may glorify Thee in all our ways so that when our labor on earth shall end, we, too, may be raised to endless, fadeless light in Thy Eternal Home and Thine, O Righteous Father shall be the glory forever. AMEN.

(The deceased Brother's Masonic record may then be read, and appropriate remarks given by the Brother in Charge or by a Brother appointed by the Master.)

The Officiating Brother shall then continue:

Life is a gift from our Maker; a Divine spark kindled in mortal Clay; a gleam of light; a vision of gladness and then back to its Creator in everlasting fellowship. What each man crowds into his short period of time is his memorial. It is indelibly imprinted upon the hearts of those who were privileged to enjoy his fellowship. As a

Mason our Brother was taught to give of the fruits of his labor to the distressed, to strengthen the irresolute, to befriend the orphan, to lend guidance to his fellow man and to walk humbly with his God.

(If not in charge at the grave the apron and evergreen section of part two should be used at this point.)

To his relatives and friends, we, as Masons can truly say that we deeply, sincerely and affectionately share your bereavement and we commend you to the loving care of our Heavenly Father, who looks down with infinite compassion upon His children and holds in His arms of love and protection all those who put their trust in Him.

Let us pray.

(By the Brother in charge, the Chaplain or other designated Brother) Gracious and merciful Creator of all mankind grant that we, Thy workmen, may be faithful to the tasks assigned us. Strengthen the good in us and help us to master evil and be ever ready to go to the aid of the distressed, so that, when we come to the end of our earthly labors we may merit Thy “well done.” Comfort we beseech Thee the hearts that are heavy with sorrow; befriend them in their loneliness. May the light of Thy love abide with them and grant them faith to look beyond this day of mourning to Thy Heavenly Kingdom where sorrow is unknown, broken friendships renewed and unfinished tasks brought to fulfillment. AMEN.

**BENEDICTION:** (By the Brother in charge, the Chaplain or other designated Brother) Now may the presence, comfort and strength of our Heavenly Father and the peace that passeth all understanding abide with us all, now and always. AMEN.

## PART II

To be used at the place of interment.

From time immemorial it has been the custom among the Fraternity of Ancient, Free and Accepted Masons, at the request of a Brother or his family, to accompany his body to the place of interment and there deposit it with Masonic Rites. In keeping with this

custom we are here as Masons to offer this tribute of our affection and thereby show the sincerity of our esteem for him and our faith in our Fraternity.

The Lambskin or white apron (here display it) is an emblem of innocence and the badge of a Mason. It is acknowledged by us to be the highest honor that we can confer. It was the first gift of Masonry to our Brother, and now in tender memory this spotless garment we leave with him. (places it on his casket) The Masonic apron is accepted by us as a symbol of purity of life and conduct toward which we strive.

The Evergreen (here display it) is an emblem of our faith in the immortality of the soul. By it we are reminded of our high and glorious destiny and that there dwells within our tabernacle of clay an immortal spirit over which the grave has no dominion and death no power. In tender memory, this, too, we leave with him. (Evergreen deposited on casket)

(If given in part I service the following paragraph need not be repeated.)

To his relatives and friends we can most truly say that we deeply, sincerely and affectionately sympathize with you in your bereavement and commend you to the loving care of our Heavenly Father Who looks down with infinite compassion on His children and folds in His arms of love and protection all those who put their trust in HIM.

The spirit of our Brother having been called to its Heavenly Home we leave him in the hands of our Heavenly Father who doeth all things well. Friend and Brother (here give first name of Brother) we bid thee an affectionate farewell in the faith of joining thee in that temple not made with hands, eternal in the Heavens.

**BENEDICTION:** (By Brother in charge, Chaplain or other designated Brother) May the blessing and comfort of our Heavenly Father be and abide with us all and give to each of us courage, strength and fortitude to meet and perform life's appointed tasks so that when we depart this life we may enter into eternal life, rest and peace in our Heavenly Home. AMEN.



## A Private Memorial Service

To be used at a Stated Communication of a Masonic Lodge after the demise of a Brother. (If there is more than one Brother plural verbs and nouns shall be used.)

**Master:** The roll of the workmen has been called and one Master Mason has not responded to his name. (Brother, if buried elsewhere, use the words “we are informed that) Brother has laid down the working tools of the Fraternity” and (if buried elsewhere use the words ‘that he’) has been summoned to the Sublime Lodge by the Grand Master of us all.” Brother Secretary, will you read his Masonic record? (Here may be given a brief obituary or eulogy of the departed Brother.)

(The following may be substituted for the preceding paragraph, if this service is used annually for all deceased Brethren during the year).

**Master:** Brethren, the roll of the workmen has been called and several Master Masons have not responded. It is because they have laid down the working tools of the Fraternity. They were summoned to the Sublime Lodge by the Supreme Grand Master of us all. Brother Secretary, you will read their names and Masonic Records. (Done)

**Master:** Brethren, we offer our tribute of esteem for Brother (or Brothers) (Here a brief tribute may be given.) The record of his earthly journey is closed. We are grieved by his passing, yet we rejoice because during his years among us he embraced the tenets and ideals of our Fraternity. His life and ours were enriched by our fraternal ties. Now we commend him to the everlasting presence of our Supreme Grand Master. (Here the Master will call up the Lodge and say) Let us bow our heads in a moment of silent tribute to the departed (After a moment of silence) Brother Chaplain will you lead us in prayer.

**Chaplain:** Let us pray. Almighty God in whom we live and move and have our being, we give Thee hearty thanks for the life of him (or them) whom thou hast called again Unto Thyself. We are

grateful for our labors together as Master Masons. We are thankful for the ideals and purposes which caused us to aspire to better things; for ties that bound his soul (or their souls) to ours; for the good he did (or they did) and the services he rendered (or they rendered) to us, to all who were dear to him (or to them) and to his fellow men (or their fellow men). We thank Thee for knowledge of the deeper meanings of life which assures us of its oneness and continuity, and that our earthly life is but a phase of that ongoing life which we share with Thee. Grant that our souls may be comforted and strengthened by the thoughts and experiences of this hour. May we go from this place with a deeper sympathy, a greater charity, a firmer faith and more earnest intentions, so that we may be enabled to govern our thoughts, words and deeds in such a manner that at the last, we, too, may stand in Thy presence as workmen that need not be ashamed. AMEN.

### **A SHORT BURIAL SERVICE.**

For use at the grave during inclement weather.  
Compiled From the Standard Masonic Monitor.

(All being in place around the grave, the service begins with prayer)

#### **Prayer**

**Master:** —Almighty and most merciful Father, as it has pleased Thee to take from us one dear to our hearts, sanctify and bless unto us this dispensation of Thy providence. Inspire our hearts with wisdom from on high, that we may glorify Thee in all OUR ways. And when our labor on earth shall end, may we be raised to the enjoyment of fadeless light and immortal life in that kingdom where faith and hope shall end. And Thine, O righteous Father, shall be all the glory forever. Amen.

**Response:** So mote it be.

**Master:** —Brethren, we have assembled today as Masons to offer to the memory of our deceased Brother this last tribute of our affection. Unto the grave we consign this body – earth to earth – ashes to ashes – dust to dust, looking for the general resurrection of the dead, and the life of the world to come.

**Master:** (holding apron) The Lambskin or white leather apron is an emblem of innocence and the badge of a Mason, which we now leave with him. (Place apron on coffin.)

**Master:** (holding evergreen) This evergreen is an emblem of our faith in the immortality of the soul. By it we are reminded that we have an immortal part within us, which shall never, never, never die.

(Master places evergreen on coffin.) Alas, my Brother.

**Master:** —To the relatives and friends who are most heart-stricken at the loss they have sustained, we can most truly say that we sincerely, deeply and most affectionately sympathize with you in your bereavement, and commend you to the loving care of our Heavenly Father, Who looks down with infinite compassion upon the widow and fatherless in their desolation and Who will fold the arms of His love and protection around those who put their trust in Him.

(A prayer may then be offered, which concludes the ceremonies at the grave.)

## **CHAPTER XII**

### **LODGE OF SORROW**

Final Masonic Rites should always be conducted at a Special Communication opened on the Master Mason degree. The Lodge may be opened for each such occasion, if the Master so desires, or a Lodge of Sorrow can be opened at the beginning of the year and remain open for the purpose of conducting Final Masonic Rites.

The Lodge of Sorrow should be opened at the first stated meeting after installation of Lodge officers. The Lodge of Sorrow can then remain open for the entire year and be closed either at the last stated meeting of the year or at a Special Communication held prior to the next installation of officers.

The following ceremony for opening the Lodge of Sorrow is a suggested form that can be used at the discretion of the Master. Any and all parts of this suggested ceremony can be modified, eliminated, or replaced to fit the needs and desires of the Lodge.

The Lodge having been opened on the Master Mason degree, the following ceremony is conducted at some convenient time.

#### **CEREMONY FOR OPENING A LODGE OF SORROW**

W.M. "Brethren, we will now proceed to open our Lodge of Sorrow for the coming year. Brother Senior and Junior Wardens, please assist me." (Wardens stand)

W.M. "Brethren, the Lodge of Sorrow reminds us that in the midst of life we are near death, and we know not when the summons of death may come to one of us."

S.W. "We walk in the light while we have the light, but the darkness of death may come upon us at a time when we are not prepared."

J.W. "We know not when the Master will call; at evening, at midnight, or in the day. Therefore we should govern our lives that we

may be found worthy to be called from labor in this world to refreshment in that glorious and celestial Lodge above. “

W.M. “We open this Lodge of Sorrow, and hold it open for a year, so that, should the hand of fate strike a Brother from among us, we may be in readiness to perform our duties and pay tribute to his memory by the Ceremonies of our Ancient Craft. \* \* \* Brother Chaplain, let us pray.”

Ch. “Almighty and Eternal God, in Whom we live, and move, and have our being, we pray that Thou will grant each of us health, happiness, and well being in the coming year. We hold the hope that each of us and all our Brothers whom we hold dear, will be present when we close this Lodge of Sorrow at the end of its appointed time. But should it be your will to call for workmen from among our ranks, then help those remaining to see the Wisdom in Your choice. (Chaplain may add further words as he sees fit.) AMEN”

W.M. “I now declare the Lodge of Sorrow of Lodge number open for the year , its labors to assume as they may be required.” \*

The Lodge of Sorrow should be properly closed at the end of its year of labors by a ceremony that is appropriate to the tasks it has been called upon to perform. If any Brethren have died during the year, it is appropriate to hold a memorial service in their memory, and to do this in conjunction with the formal closing of the Lodge of Sorrow. This ceremony can be conducted at the last Stated Communication of the Master’s year, or at a Special Communication called for the purpose. In either case, the families and friends of the deceased can be invited to the Lodge to take part in the ceremony.

The Lodge having been opened on the Third Degree, the Master states the purpose and proceeds. If family and friends are to take part, the Master will declare the Lodge at recess for the purpose of public ceremony and the guests will be invited in and seated. Columns and lights will be disposed as in open Lodge. The words

for the Masonic Funeral Dirge should be distributed to all in attendance.

The ceremony then proceeds as follows:

Read the pertinent minutes of the past year. Refer to the General Regulations.

### **MEMORIAL SERVICE FOR CLOSING THE LODGE OF SORROW**

W.M. What man is he that liveth, and shall not see death? Shall he deliver his soul from the hands of the grave?

S.W. Man walketh in a vain shadow. He heapeth up riches and cannot tell who shall gather them.

W.M. When he dieth, he shall carry nothing away; his glory shall not descend after him.

J.W. Naked he came into the world, and naked he must return.

W.M. The Lord gave, and the Lord hath taken away; blessed be the Name of the Lord.

W.M. Brethren and friends, please join me in a circle around the altar of our Craft.

(All present rise and form a circle with the altar at its center. The room lights are dimmed, the altar spot light remains on. The Master stands at the East side of the altar. When all are in place the Master then reads Ecclesiastes xii, verses 1-7 from the open bible upon the altar. After the reading, all present join in singing the Funeral Dirge.)

### **FUNERAL DIRGE**

**Air: Pleyel's Hymn**

(See Chapter XV for music and words to Pleyel's Hymn)

Solemn strikes the funeral chime,  
Notes of our departing time,

As we journey here below  
    Through a pilgrimage of woe.  
Mortals, now indulge a tear,  
    For Mortality is here!  
See how wide her trophies wave  
    O'er the slumbers of the grave.  
Here another guest we bring,  
    Seraphs of celestial wing!  
To our funeral altar come  
    Waft our friend and brother home.  
Lord of all! below,—above,—  
    Fill our hearts with truth and love;  
When dissolves our earthly tie  
    Take us to thy Lodge on high.

W.M. Let us pray.

Ch. Thou, O God! knowest our down-sitting and our uprising, and understandeth our thought afar off. Shield and defend us from the evil intentions of our enemies, and support us under the trials and afflictions we are destined to endure, while traveling through this vale of tears. Man that is born of a woman, is of few days and full of trouble. He cometh forth as a flower, and is cut down; he fleeth also as a shadow, and continueth not. Seeing his days are determined, the number of his months are with Thee; Thou hast appointed his bounds that he cannot pass; turn from him, that he may rest, till he shall accomplish his day. For there is hope of a tree, if it be cut down, that it will sprout again, and that the tender branch thereof will not cease. But man dieth and wasteth away; yea, man giveth up the ghost, and where is he? As the waters fail from the sea and the flood decayeth and drieth up; so man lieth down, and riseth not up till the heavens shall be no more. Yet O Lord! have compassion on the children of Thy creation, administer them comfort in time of trouble, and save them with an everlasting salvation. AMEN.

**Response:** So mote it be. (W.M. returns to East - seats Lodge).

W.M. Brother Secretary, call the roll of the workmen.

Sec. (The secretary reads the names of all the brothers present at the service, and each responds as his name is called. The names of the deceased brothers are inserted during the roll call and no response is given to their names.)

W.M. The roll of the workmen has been called and Brothers have not answered to their name. They have laid down the working tools of our ancient craft and have been summoned to the Sublime Lodge by the Supreme Grand Master of us all. No longer do they labor among us, guided by the three Great Lights of Masonry. Their days are now illuminated by the far greater light which we all know. Brother Secretary, read the Masonic records of these Brothers.

Sec. (Reads names and Masonic records of deceased Brothers.)

W.M. Life is a gift from our Maker, a divine spark kindled in mortal clay, a gleam of light, a vision of gladness, then back to its maker to dwell in everlasting fellowship. We journey through the days of our lives as if we were totally unaware of our inevitable fate. Yet, which of us can be sure of greeting tomorrow's sunrise? And who among us may be the focus of our most solemn ritual? No one may know in advance when he will be called to make that journey, naked and penniless, carrying only that which he has made of himself. In the memory of our Brothers who have set out upon this journey, let us pray.

Ch. Most glorious and merciful Lord God, our Heavenly Father! Author of all good, and giver of all mercy! Pour down, we implore Thee, Thy blessing upon us, and under the deep solemnities of this occasion, bind us yet closer together in the ties of brotherly love and affection. May the present



instance of mortality remind us of our approaching fate, and draw our attention toward Thee, the only refuge in time of need. Bless each one of us by the comforting and strengthening of our souls, in the thoughts and experiences of this hour. May we go forth from this place with deeper sympathy, warmer love, stronger faith, more earnest purpose.  
AMEN

W.M. May we hold dearly, in our minds and hearts, the memory of those who have passed this year. I now declare the Lodge of Sorrow for duly closed and its labors complete.”

## CHAPTER XIII

### RECEPTION OF VISITORS BY A LODGE

The reception of Grand visitors with the honors due to their rank is an ancient custom of the Fraternity, which should never be omitted. It is an act of great discourtesy to a visiting Grand officer, to omit his formal reception by the Lodge, except at his express wish. The Grand Master or his representative should require it. Even when such visit is unofficial it will be found to greatly increase a true fraternal feeling when this courtesy is properly shown. When a visit from the Grand Lodge, Grand Master or his proxy, Deputy Grand Master, or a Grand Warden, is expected, a suitable room should be provided for their use, if possible.

#### I. – The Grand Master

When the Tyler announces the presence of the Grand Master, as he should, the Master sends out the Marshal, Deacons, Stewards, and one of the oldest members (a Past Master, if possible) bearing the Book of Constitutions, to escort him, and any Grand Officers accompanying him, into the Lodge room. The most frequent practice is to have a Past Master act as the Marshal. They form a procession in the following order:

Marshal  
Stewards  
Grand Officers  
Brother with the Book of Constitutions  
Grand Master  
Deacons.

*(See the diagram on the following page)*

When the procession enters the Hall, the Stewards will halt, cross their rods, the Marshal will announce: “The Most Worshipful Grand Master of Masons of Minnesota.” The Lodge is then called up. The procession passes by the Stewards to the altar. On arriving at the

## Diagrams for the Order of March for Reception of the Grand Master

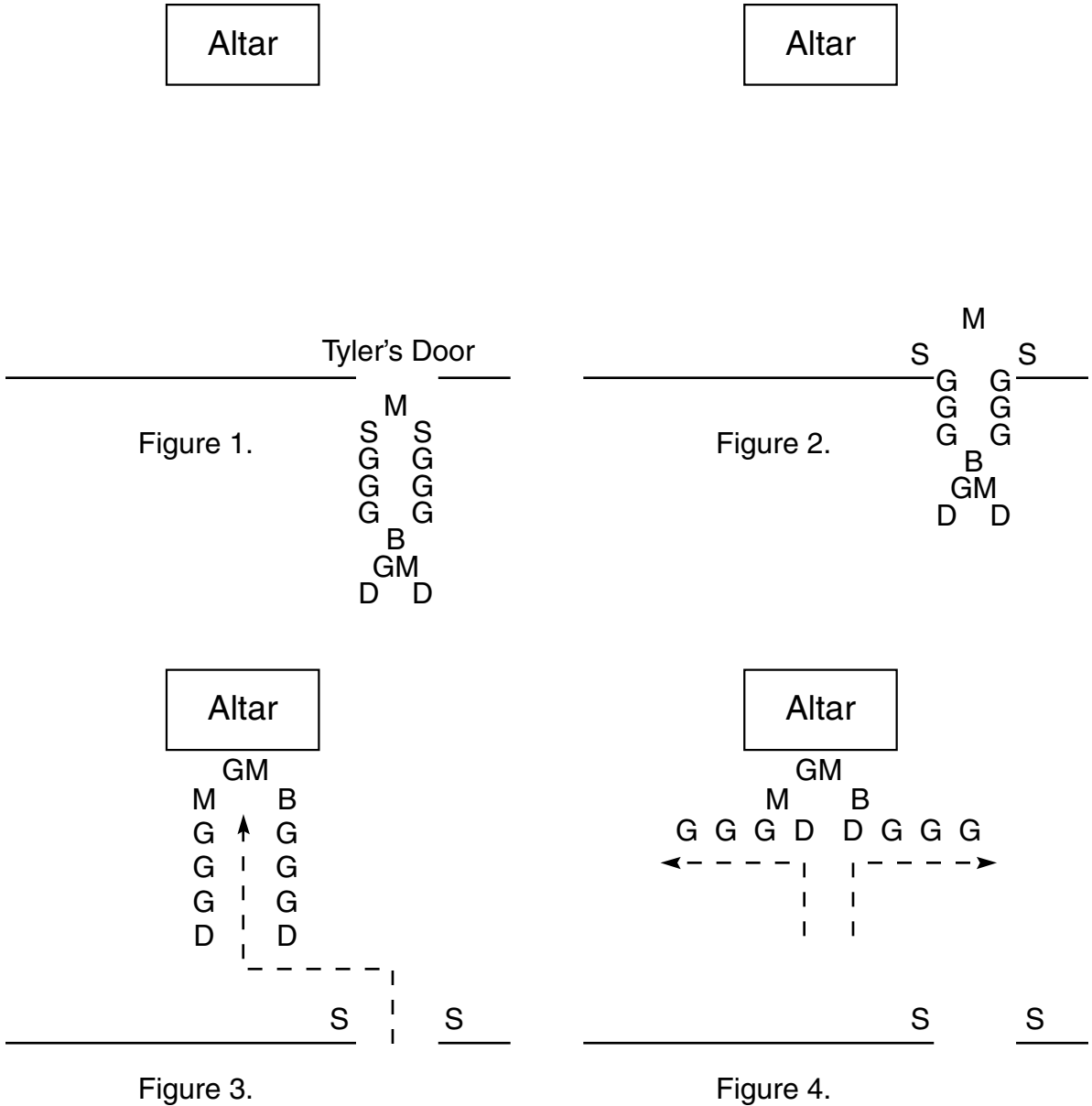

- M – Marshal
- S – Stewards
- G – Grand Officers
- B – Brother with the Book of Constitutions
- GM – Grand Master
- D – Deacons

altar the other officers, if any, open ranks and face inward, the Grand Master passes through to the altar, while they, filing right and left, form a line across the Hall. The private Grand Honors are then given. The Master advances to the altar, and extending his hand, gives the Grand Master a cordial welcome, tenders him the gavel, and conducts him to the East, and the Master uncovers. The other Grand Lodge Officers are given seats in the East, and the Lodge is seated. The Grand Master may decline to receive the gavel or chair, or may resign them at any time at his pleasure. Should he wish to retire, the Lodge is called up, the same Grand Honors are given, and he and his suite are escorted as before, to his apartment.

Should the Grand Lodge (the Grand Master, all the Grand Lodge Officers and others entitled) pay a visit as such, their reception will be similar to that accorded the Grand Master.

The form of reception to be given the Deputy Grand Master, Grand Wardens, or the Grand Master's proxy, on being announced as an Official Visitor, he will be substantially the same as for the Grand Master, except that the Book of Constitutions will not be borne before them.

## **II. – Other Brethren**

When a brother Mason visits a Lodge he must be examined or vouched for. Great care should be exercised before admitting any unknown brother. None such should be permitted to visit a Lodge, unless a member in good standing of some lawful Lodge. The law of this jurisdiction (found in the General Regulations) is strict, in regard to visitation. The visitor must produce a receipt or certificate not more than a year old, showing his Masonic standing in a regular Lodge, which will be ascertained by reference to the Official List of Regular Lodges furnished by the Grand Lodge. The visitor's name, Lodge, and residence, should be sent by the Tyler to the Master, who will appoint a committee of two to retire and examine him. He should, after giving in writing his name, Lodge and its location, then

take the test oath. The committee will examine him, and test his knowledge of the degrees and work in general, after which they will return and report in full to the Master, who will then decide whether to admit him or not. If he is to be admitted, the Master will send the **SENIOR DEACON** to introduce him, who will receive him at the door, conduct him to the altar and say:

Worshipful Master, I have the pleasure of introducing to you Brother \_\_\_\_\_, of \_\_\_\_\_ Lodge, No. \_\_\_\_\_, at \_\_\_\_\_.

(The Master calls up the Lodge and says:)

Brother \_\_\_\_\_, it gives me pleasure to introduce you to the members of \_\_\_\_\_ Lodge, No. \_\_\_\_\_, and to welcome you to a seat among us. We meet on \_\_\_\_\_, and shall be very glad to welcome you to any of our meetings. Brother Senior Deacon, conduct the brother to a seat. (This is done and the Lodge is then seated.)

If the visitor is a Past Master he should be invited to a seat in the East, and if he is an officer of any Grand Lodge or prominent member of our own Grand Lodge, he should be received with the Grand Honors at the time of his introduction.

While a formal introduction is not expected or necessary after the first visit, yet the Master should take great care to extend the proper courtesies to visiting brethren at all times, and to make them feel that they are indeed welcome.

He should invariably, as soon as the Lodge is opened, give a general invitation to all Past Masters to take seats in the East if there is room for them, and this invitation should be accepted by those present, especially if visitors, unless there are special reasons for not doing so.

An Entered Apprentice or Fellowcraft Mason can visit only on those degrees and then only in company with a Master Mason who actually saw him take them.

**CHAPTER XIV**  
**SUGGESTED CEREMONIES**  
**FOR PRESENTATIONS**

**FIFTY YEAR EMBLEM**

At the time the presentation is to be made, which should be in open Lodge, the Master should proceed as follows: (Use plural when applicable.)

**MASTER:** Our installation ceremony includes a statement that the duties of a Master are many and various – some of those duties are arduous and difficult, others fall in the class of pleasant experiences. It is, tonight, my very pleasant duty and privilege to announce that the completion of fifty years of membership by one of the brethren of this Lodge has been recognized by the Grand Lodge of Minnesota.

Brother Marshal (Marshal rises and salutes) — you will conduct Brother \_\_\_\_\_ to the Altar. (done) (Master calls up the Lodge, proceeds to the Altar, clasps the hand of the Brother and says: Brother \_\_\_\_\_, we are delighted that you have found it possible to be present to allow the brethren of your Lodge to participate in the honor that is to be yours this evening — permit me to conduct you to a seat in the East.(done) The Master then says: Brethren, I present Brother \_\_\_\_\_ who is present, to receive recognition of his fifty years of membership. (Applause by the brethren). Master seats himself, seats Lodge.

**MASTER:** Brother Secretary (Secretary rises and salutes)—you will please read the Masonic record of Brother \_\_\_\_\_. (Secretary reads the record, including dates of initiation, passing and raising, Lodges to which the Brother has belonged and Masonic Honors, if any.)

**MASTER:** Brethren, it is with pleasure that I now present (MW, RW, W) Brother \_\_\_\_\_ representing the Grand

Lodge A.F. & A.M. of Minnesota on this very pleasant occasion.  
(G. L. Representative rises and is accorded customary applause.)

(If the Brother to be honored is active, he should be asked to rise—if aged or infirm, he should be permitted to remain seated while being addressed until the actual presentation of the emblem.)

**G. L. Rep:** Brother \_\_\_\_\_, over a half century ago you knelt at the altar of Masonry and repeated the obligations which, though old, are ever new to the faithful of the Craft. I take this opportunity of congratulating you on behalf of the Grand Lodge on this, the Golden Anniversary of your affiliation with the Sons of Light. Since your initiation into our Fraternity, you have observed many changes in our ways of life: nations have flourished and fallen, but through it all our Institution remains unchanged and unchanging. Your continuous membership of over fifty years is, in itself, evidence of your continued adherence to the tenets of Brotherly Love, Relief and Truth, and of your appreciation of the associations afforded by membership in our Fraternity. It is now my duty and my privilege as Representative of the Grand Lodge A.F. & A.M. of Minnesota to present to you this tangible evidence of the appreciation of the Masonic Fraternity as a whole and more especially that of the Grand Lodge of Minnesota and of \_\_\_\_\_ Lodge No. \_\_\_\_\_ of your faithful observance of the obligations taken by you so many years ago, and we sincerely trust that as you continue your journey along life's highway, the knowledge that you have been and still are appreciated and held in esteem by your Masonic Brethren will afford you pleasure and that you will, as admonished by the poet:

“Grow old along with me,  
The best is yet to be.  
The last of life,  
For which the first was made.”

(Affixes emblem – clasps honored Brother's hand and allows him an opportunity of making any remarks if he so desires.)

(At the conclusion of the Brother's remarks, if any, the G. L. Rep. should address the brethren in accordance with his desires, after which he thanks the Master and is seated, and the Master continues with the business of the evening.

### **MASONIC WIDOW'S PIN**

The Grand Lodge of Minnesota MASONIC WIDOW'S PIN was created to formally honor and recognize the widow of a brother to whom the Craft owes special ties of care and concern. Annually each Constituent Lodge is encouraged to include the presentation of this pin in a program as a "Widow's Night" or in conjunction with another special evening when it would be appropriate to invite the widows of the Lodge to come as guests of the Lodge.

It is highly recommended that this evening emphasize the special place with which we hold the widows of our Lodge. Timely preparation should be given to the planning and incorporation of the widows into the program. If possible, the widows should be given formal invitations signed by the Master of the Lodge along with a request that they will be chauffeured to the Lodge as special guests. If a dinner is to be served it is expected that the widows will be the guests of the Lodge.

Program for a Widow's Night could be as follows:

1. Welcome by the Master of Ceremonies and if a dinner is held, the invocation is given prior to the meal.
2. Master of Ceremonies introduces escorts for flag if any, and leads the audience in the pledge of allegiance.
3. Master of Ceremonies introduces the Master of the Lodge.
4. Master welcomes members and friends and introduces lodge officers and special guests.



5. Master announces the names of departed brethren during the preceding year and gives a brief summary of the positions, duties or contributions of the individual brothers to the Lodge.

6. Master invites the widows to come forward and reads the following address concerning the Masonic widow's pin:

This pin was created as an emblem to symbolize our continued concern and honor for the widow of a Brother Master Mason, a Brother whose name added luster to the Craft as he labored with us in the Quarry. Now that his name has been entered upon the Roll of the Celestial Lodge, we cannot forget those things which he loved so deeply, nor can we be unmindful of our duty to him. It is my distinct privilege to present this emblem to you that you may wear it with great pride. It is our desire that it be to you a reminder of your ties to us: a relationship wherein you will find friends who will assist you in times of need, join with you in times of gladness, and welcome you to a continued association with us as we continue our labors of Friendship, Brotherly Love and Truth.

You are not alone. When moments may cause you to doubt, look at this emblem and be assured that we are there and we care.

(At this point the Masonic Widow's Pin is pinned on the outer garment of each widow so as to be in plain view. After which the following is to be spoken.)

This Masonic Widow's Pin was created with the hope that it would be worn by the widow of a Master Mason on all appropriate occasions, especially when traveling, so that she may be recognized, greeted, and assisted when necessary, by Masonic friends throughout the world. It is an emblem of honor and should be worn separately, and not in conjunction with other jewelry.

May she who wears this emblem find that she is not alone. We are there and we care.

7. Following the reading it would be appropriate to have the audience recognize the awarding of this pin with their applause. Time should be also be given before the widows are seated to ask if they have any comments. Some may be so overcome with emotion and the memories of the passing of their husband that they will be unable to respond. Others may want to share something about the importance of Masonry in the life of their deceased husband or the circumstances of their husband's death and the support which the Lodge gave at that time. Such remarks, if volunteered, are quite appropriate and make the evening more meaningful.

8. Appropriate entertainment or a guest speaker (ideally sharing something about the meaning, symbolism or charity of the Craft) could conclude the program. Recognition should be given to all of those who helped to make the program a success.

The Masonic Widow's Pin, with a card backing which gives the formal presentation address cited above, is available from the Grand Lodge office. The Master and Secretary of the Lodge should sign the card which accompanies the widow's pin before presentation. They should be ordered in ample time prior to the presentation.

It is highly recommended that each Constituent Lodge annually set aside an evening or event to honor the widows of the Lodge. There may or may not be presentations of new Masonic Widow's Pins, however, the significance of the event is to remind the widows and lodge members that the widows of Masons are held in special honor and deserve our first response of Masonic charity or assistance.

Along with the Masonic Widow's Pin, the Grand Lodge of Minnesota has created a Masonic Memorial Booklet titled "A Tribute of Our Affection." This booklet, which has parts of the funeral or memorial service and prayers conducted for a deceased brother by the Lodge, may be given to the widow of a Master Mason on the same evening that the Masonic Widow's Pin is presented. This

memorial booklet may also be purchased through the Grand Lodge office and should be filled out by the Lodge Secretary with the deceased brother's Masonic history and signed by the elected officers of the Lodge.

## **HIRAM AWARD**

The Grand Lodge of Minnesota HIRAM AWARD is a singular, once-in-a-lifetime recognition presented to a brother as an earned tribute for outstanding service to Freemasonry. The Master of every constituent Lodge in Minnesota is entitled to recognize one brother with this special distinction during his term of office. The local lodge should determine the criteria and method of selection. The HIRAM AWARD should not be presented posthumously. The Master of the lodge could appoint a committee of at least three to recommend possible recipients and coordinate all aspects of the program.

It is highly recommended that a special evening be planned for the presentation of this award. This is not the time to combine several award presentations into one celebration. Each dedicated brother selected for the HIRAM AWARD deserves individual recognition. His years of devoted contributions to the Craft entitle him to a night when he alone enjoys a few moments in the spotlight of applause from his brothers, family and friends. This is not designed to be a "surprise" award, for this would deprive a brother from inviting friends, family and others only he would know.

The evening should be well planned and publicized months in advance. Scheduling of the HIRAM AWARD gives your lodge an excellent opportunity to show off your lodge rooms to non-Masonic guests. The name of the recipient would be the principle attraction, as his service to others would be immediately recognizable.

A dinner for the evening would be most appropriate. An invocation should be given before dinner. If your lodge dining room is too small to accommodate a crowd, don't hesitate to find a larger

facility. Try to avoid having your HIRAM AWARD ceremonies in the lodge dining area. If possible stage your program in the Lodge Room.

HIRAM AWARD events are ideal times to invite members of the youth orders to participate in the flag salute, help with serving, etc. Don't forget to give them credit and introductions. If at all possible, the Master, lodge officer's and distinguished guests are encouraged to wear tuxedos or formal attire. The evening is to be dignified. Occasionally, some type of entertainment might be injected into the program, however, **IT IS THE HIRAM AWARDEE'S SPECIAL NIGHT AND NOTHING SHOULD DETRACT FROM HIS RECOGNITION.**

A suggested program could be as follows:

1. Master of Ceremonies introduces escorts for flag if any, and leads the audience in the pledge of allegiance.

2. Master of Ceremonies introduces the Master of the Lodge.

3. Master of the Lodge welcomes members and friends and introduces the lodge officers and any special guests.

4. The Master of Ceremonies invites various brethren and friends to talk about the recipient. This is very important to do! **BE CREATIVE!** Under no circumstances should the evening be planned as a "roast" of the recipient. Careful preplanning is vital for a successful program. Alert the honoree's friends, family members and Lodge brethren to be ready to speak briefly about him.

5. The Master of Ceremonies recognizes the Grand Lodge representative who has been invited (with a brief fraternal background) and calls for comments on "what the HIRAM AWARD represents." As a representative of the Grand Master, he will pass the framed certificate to the Master of the Lodge. (The constituent lodge is to see that the certificate is suitably framed for presentation.)

6. The Master of the Lodge invites the HIRAM AWARD recipient and his spouse forward and makes a brief presentation on

behalf of the Lodge. He then presents the HIRAM AWARD certificate to the recipient and invites the audience to join him in a standing vote of appreciation.

7. The recipient of the HIRAM AWARD responds with his comments.

8. Any closing remarks may be made by the Master of Ceremonies or the Master of the Lodge (i.e. invitation for refreshments, thank you for attending, etc.).

9. The formal program should conclude with a closing prayer. If entertainment is to be utilized, it should occur between numbers 3 and 4 above. Nothing should detract from the actual honoring of the recipient.

The Grand Lodge firmly supports the recognition of your nominee. We encourage you to take pictures and publicize this recognition in your local newspapers and lodge trestleboard. Publicize the fact that the brother selected for a HIRAM AWARD is being singled out as your local Lodge's choice for personal tribute. The success of an outstanding HIRAM AWARD event is vitally dependent upon how much effort and enthusiasm are generated by all your members, not just a few committee members. Throughout the years, keep a history of the recipients. Your lodge may wish to purchase a special plaque to hang in the lodge with each recipient's name engraved on it and the year of the award.

### **PROCEDURE FOR ORDERING THE HIRAM AWARD**

Each HIRAM AWARD certificate should be ordered from the Grand Lodge office at least one month in advance. Send the name of the recipient, intended date of presentation, and a brief statement on why this individual has been selected to receive this award.

The Grand Lodge will have the recipient's name suitably lettered on the certificate and will forward it to the constituent lodge.

The lodge should have the certificate suitably framed for presentation. The certificate should never be presented without a frame as this would greatly detract from the dignity of the presentation. A standard 11 x 14 inch frame will nicely fit the award, or it can be matted to allow for an even larger frame.

### **SUGGESTED PRESENTATION BY THE MASTER OF THE LODGE:**

The Grand Lodge of Ancient Free and Accepted Masons of Minnesota bestows the HIRAM AWARD upon a Mason who has served his Lodge with distinction over a period of time. The Master of each constituent lodge may recommend one brother for this peculiar and special honor only once each year. We at \_\_\_\_\_ (name of lodge) have chosen a committee to determine fairly and objectively whether we have a brother deserving of this once-in-a-lifetime distinction. It is with great Masonic and personal pride that I announce the presentation of the HIRAM AWARD to Brother \_\_\_\_\_ (name of recipient).

You may ask, “Why HIRAM?” Who is this HIRAM and why do masons choose this name for the award?

The Bible records that Hiram of Tyre was a famous artisan and builder at the construction of King Solomon’s Temple in Jerusalem. In the Old Testament we read of Hiram in the First Book of Kings and the Second Book of Chronicles. King Solomon, in chapter 2 of the Second Book of Chronicles, “determined to build a house for the name of the Lord and a royal residence for himself,” and Solomon sent word to Hiram or Hiram King of Tyre announcing his intentions and requesting his assistance. In response King Hiram sent building materials and his most trusted architect Hiram along with a letter of introduction which described his skills. In part, the letter read, “Now I have sent a skilled man endued with understanding,

Hiram abi' son of a woman of the daughters of Dan, and his father was a man of Tyre. He is trained to work in gold, silver, bronze, iron, stone and wood, AND in purple, blue and crimson fabrics and fine linen, and to do all sorts of engraving and to execute any design that may be assigned to him." He is further described as a cunning workman and leader who could accomplish any task assigned to him. Truly this is the description of a remarkable person.

We as Masons, have adopted the framework of building King Solomon's Temple, and the remarkable accomplishments of Hiram Abif as the central theme of our Masonic ritual. The character of Hiram who unselfishly applied himself to honor his god, better the conditions of his fellows, and who ultimately offered up his life rather than forfeit his integrity is revered by Masons and therefore forms the basis for the high honors which we confer this evening.

As we apply the biblical description of Hiram the builder to Masonry, we occasionally identify among the brethren members who cheerfully take on any task assigned to them and accomplish it fully. Our honoree this evening is such a person. Since becoming a Mason in \_\_\_\_\_ (year), \_\_\_\_\_ (recipient's name) has been asked to assume many responsibilities, and has volunteered for many more. At this time I would like to ask Brother \_\_\_\_\_ (name) to join us and provide a short list of our honoree's achievements in Masonry. (Masonic record and achievements are read by the assisting Brother.)

Brother \_\_\_\_\_ (recipient's name), on behalf of the members of \_\_\_\_\_ Lodge, it is with great personal pride that I present you with our Lodge's HIRAM AWARD for \_\_\_\_\_ (year).

## CHAPTER XV

### MUSICAL NOTES

#### Melodies (Airs) for Masonic Odes

Some of the melodies for the Masonic Odes given in the Minnesota Masonic Manual are very old and subsequently out of print or very hard to find. We have taken the liberty to substitute some new hymn tunes with words and music which is more familiar and which are reprinted in this section.

The lodges are encouraged to incorporate music into the ritual of the lodge work whenever it can be done with decorum and good planning. It is essential that if the music is to be sung by the brethren or by a soloist or ensemble that it be rehearsed. This can easily be done if musical accompaniment is provided and a few minutes of time are taken prior to the ritual work to rehearse the music. The inclusion of instrumental or vocal music, when well done, will add immeasurably to the meaning of the ritual work and give a wholesome and good affect for all who hear or are participating.

The Grand Lodge Bookstore also carries "Masonic Music for Lodge Degrees" on four cassette tapes, which may be incorporated in the ritual degree work.

#### **HYMN TUNES REPRINTED INCLUDE:**

AULD LANG SYNE . . . . .	page 137
Scotch Air, Words: Robert Burns	
HANKEY 76.76.D . . . . .	page 138
Music: William D. Fischer, 1869	
SWEET HOUR LMD . . . . .	page 139
Music: William B. Bradbury, 1861	
PLEYEL'S HYMN 77.77 . . . . .	page 140
Music: Ignace J. Pleyel, 1757-1831	
AZMON CM . . . . .	page 141
Music: Carl G. Glaser; arr. by Lowell Mason, 1839	



# AULD LANG SYNE

ROBERT BURNS

SCOTCH AIR

1. Should auld ac-quaint-ance be for - got, And nev - er bro't to mind? Should  
2. And here's a hand my trust - y frien', And gie's a hand o' thine; We'll

The first system of the score consists of two staves. The upper staff is in treble clef and the lower staff is in bass clef. The key signature has two flats (B-flat and E-flat), and the time signature is 4/4. The music is written in a simple, folk-like style with chords and single notes.

REFRAIN

auld ac-quaint-ance be for - got, And days of old lang syne? For auld\_\_ lang\_\_  
tak' a cup o' kind-ness yet, For auld\_\_ lang\_\_ syne.

The second system of the score is the first line of the refrain. It continues with two staves in the same key and time signature as the first system. The lyrics are written below the notes, with some words underlined to indicate a long note.

syne, my dear, For auld lang syne; We'll tak' a cup o' kind-ness yet For auld\_\_ lang\_\_ syne.

The third system of the score is the second line of the refrain. It continues with two staves in the same key and time signature. The lyrics are written below the notes, with some words underlined to indicate a long note.

Original Scotch: <sup>1</sup>fere (Companion) <sup>2</sup>And we'll tak' a richt gude-willie waught. (And we'll take a draught with right good will.)

1. His laws in-spire our be - ing, Our light is from His  
 2. Thou, Fath - er art the Giv - er, To ev - ery earn - est  
 3. With - in they cham-ber name him, A work - man wise and

Sun, Be - neath the Eye All - see - ing Our Ma - son's work is  
 prayer, Oh be the Guide for - ev - er, To this our broth - er  
 true - While lov - ing Crafts shall claim him, In bonds of friend-ship

done. His plumb-line in up - right - ness, Our faith - ful guide shall  
 dear! By law and pre - cept ho - ly, By to - ken, word and  
 due. Thus shall these walls ex - tol thee, And fu - ture ag - es

be, And in the source of bright-ness, Our will - ing eyes shall see.  
 sign, Ex - alt him, now so low - ly, Up - on this grand de - sign.  
 prove, What Ma - sons joy to call thee, The God of Truth and Love.

SWEET HOUR  
LMD

1. Let us re - mem - ber in our youth, Be - fore the  
2. Let us in youth re - mem - ber Him! Who formed our  
3. In youth to God let memor - y cling, Be - fore de -

e - - vil days draw nigh, Our Great Cre - a - tor  
fra - me and Spir - its gave; Ere win - dows of the  
sire shall fail or wane; Or e'er be loosed life's

and His Truth, Ere mem - ory fail and plea - sures fly;  
mind grow dim, Or door of spe - ech ob - struc - ted wave;  
sil - ver string Or bowl at foun - tain rent in twain;

Or sun or moon or plan - ets light Grow dark, or  
When voice of bird fresh ter - or wake, Or mus - ic's  
For man to his long home doth go, and mourn - ers

clouds re - turn in gloom; Ere vit - al spark no  
daugh - ters charm no more, Or fear to rise, with  
group a - round his urn! Our dust to dust a -

more in - cite; When strength shall bow and years con - sume.  
trem - bling shake, A - long the path we tra - vel o'er.  
gain must flow, And spir - its un - to God re - turn.

1. Sol - emn strikes the fun - eral chime! Notes of  
 2. Mor - tals, now in - dulse a tear, for mor -  
 3. Here an - oth - er guest we bring, Ser - aphs  
 4. Lord of all! be - low a - bove - Fill our

our de - part - ing time, As we journ - ey  
 tal - it - y is here! See how wide her  
 of cel - est - ial wing. To our funer - al  
 hearts with Truth and Love. As dis - solves our

here be - low, Through our pil - grim - age of woe!  
 tro - phies wave, O'er the slum - bers of the grave!  
 al - tar come. Waft a friend and bro - ther home.  
 earth - ly tie, Take us to Thy Lodge on high.

1. Be - hold , O, Mas - ter in the East, What  
 2. Be - hold , O, Mas - ter glor - ious arts, Were  
 3. O Mas - ter, in your sym - bolled East, Seek  
 4. O War - den, with your Lev - el poised, What  
 5. O War - den, where King Hir - am stood, Like  
 6. O War - den, with your Plumb up - raised, What  
 7. O War - den, where the Faith - ful One ob -

glor - ies greet you there; What floods of ra - diance  
 cra - dled in the East; Be - hold what sci - en -  
 wis - dom from a - bove. And spread the light which  
 les - son do you give? Are all men e - qual?  
 him, seek strength a - bove; Sus - tain the East pay  
 does the em - blem teach? Do all the Craft up -  
 served the glor - ious sun Like him a - dorn with

earth - ward stream; The sun is ris - ing fair.  
 ces came forth Man's wak - ing mind to feast.  
 heaven shall send, With - in your Lodge in love.  
 shall the worm On king and peas - ant live?  
 all their dues, Pro - tect the weak in love.  
 right - ly walk, And prac - tice what they preach?  
 Beau - ty still The work by him be - gun.

